

T&C
Power Conversion

T&C POWER CONVERSION

110 Halstead Street
Rochester, New York 14610
USA
Tel: 585.482.5551
Fax: 585.482.8487
www.tcpowerconversion.com
sales@tcpowerconversion.com

AG 1024

LF AMPLIFIER/GENERATOR



OPERATION MANUAL

www.tcpowerconversion.com
sales@tcpowerconversion.com

- This page intentionally left blank -

AG 1024

LF AMPLIFIER/GENERATOR



HIGH RF VOLTAGES MAY BE PRESENT AT THE OUTPUT OF THIS UNIT.

All operating personnel should use extreme caution in handling these voltages and be thoroughly familiar with this manual.



DO NOT USE ANY CFC (CHLOROFLUOROCARBON) SOLVENT IN THE MAINTENANCE OF THIS PRODUCT. The no-clean flux used in manufacturing this product may leave a small inert residue, which will not affect the performance of the product. The use of CFC's for cleaning or maintenance may result in partial liquefaction of the no-clean flux residue, which will damage the unit and void the warranty.

This product is manufactured at T&C Power Conversion's Rochester, NY plant, following ISO 9001 Quality System principals.



Applicable EC Directives: EC Low Voltage Directive 73/23/EEC
EC Electromagnetic Compatibility 89/336/EEC

Applicable Harmonized Standards: EN 61010-1:2001 (2nd Edition), UL 3101-1

NOTICE:

The material contained in this manual is subject to change without notice. No part of this manual may be reproduced or utilised in any form or by any means, electronic or mechanical, including photocopying or electronic transmission or other means of reproduction or distribution without prior written consent of T&C POWER CONVERSION, INC.

The drawings, specifications and other technical information contained in this manual are the property of T&C POWER CONVERSION, INC. and shall not be copied, reproduced or used in any way, in whole or in part, as basis of manufacture or sale of similar items without the prior written consent of T&C POWER CONVERSION, INC.

© 2006 T&C POWER CONVERSION, INC.

- This page intentionally left blank -

WARRANTY

T&C POWER CONVERSION, INC. warrants to original Purchaser/User for a period of 12 months from the date of delivery, each instrument to be free from defects in materials and workmanship.

For a period of 12 months T&C will, at its opinion, adjust, repair, or replace defective parts without charge to the original purchaser, so that the instrument performs according to its specification.

When warranty service is required, the instrument must be returned, transportation prepaid, to the factory.

If, in our opinion, the instrument has been damaged by accident, unreasonable use– inconsistent with user’s manual, improper site preparation or maintenance, or abnormal condition of operation – repairs will be billed at the standard rate to Purchaser.

In these cases, an estimate will be submitted to User before the work is started.

SERVICE AND TECHNICAL ASSISTANCE

For Service or Repair, contact T&C directly or a local representative with the following information:

- Model and serial number.
- Purchase order number.
- Detailed description of malfunction.

For technical Assistance for your particular application contact the factory. The following information will help us provide you with prompt and efficient service:

- All information displayed on the LCD.
- Detailed description (e.g. physical damage and/or performance anomalies, quantitative and/or qualitative deviation from specification), including miscellaneous symptoms, dates and times.
- The environment and circumstances under which the issue developed.

Supporting test data and/or records that are available.

Sales & Service Locations

Look for our currently updated Sales and Service Representatives around the world on our website:

<http://www.tcpowerconversion.com/about/representatives.html>

- This page intentionally left blank -

PRODUCT MANUAL REVISION CONTROL FORM

Document Title: AG 1024 Operation Manual Revision History Control Page

Document Number: 9081 0031

Document Status: Open

Revision History

ECO	Rev	Description	Effective Date
	A	First production release	8/2003
	B	Format update to meet EN61010-1 requirements	12/28/05
	C	Installation requirements changed	06/14/06
	D	RF Output connector redefined	07/27/06
	E	Added configuration chart to section 2.2 <i>Installation Requirements</i> . Added product ratings to section 1.14 <i>AC Input</i> and 2.4 <i>Power Line Voltage</i> .	12/04/06

	Name / Title	Signature	Date
Written By	B.J.M	<i>Boqusia J. Mokrzan</i>	12/28/05
Checked By	Alex D. Sulik	<i>Alex D. Sulik</i>	12/04/06
Approved By	Tomasz J. Mokrzan/general manager	<i>Tomasz J. Mokrzan</i>	12/04/06

- This page intentionally left blank -

TABLE OF CONTENTS

Warranty	5
Service and Technical Assistance	5
Product Manual Revision Control Form	7
Introduction	11
Chapter 1: Safety	13
1.1 Labels	13
1.1.1 Important operating or maintenance cautions	13
1.1.2 Shock Hazard Warning	13
1.1.3 Caution Warning	13
1.1.4 AC INPUT and Chassis Terminal	14
1.1.5 External RF IN	14
1.1.6 RF OUT	14
1.1.7 EDITOR	14
1.1.8 Miscellaneous Symbols	15
1.1.9 Service	15
1.1.10 Name Plate	16
Chapter 2: System Installation	17
2.1 Initial Installation	17
2.1.1 Mechanical Inspection	
2.1.2 Claim for Damage	
2.1.3 Packaging for Reshipment	
2.2 Installation Requirements	18
2.3 Cooling and Ventilation	21
2.4 Power Line Voltage	21
2.5. System Interconnection	21
2.6 Initial Turn-On Procedure	22

Chapter 3: Operation	<u>Page</u>
3.1 Front Panel Control and Display	23
3.2 Rear Panel	25
3.3 Remote Control	26
25-pin Interface Schematic Diagram	27
3.4 Rear Panel Connector Analog	28
3.4.1 Rear Panel Sub D9 RS-232 I/O Connector Signal Description Table	28
3.5 Graphic User Interface, GUI Operation	29
3.5.1 GUI Program for RS-232 Interface	30
3.5.2 Working GUI and active unit	31
3.6 Indicators	32
3.6.1 Controls	32
3.6.2 Options	33
3.7 RS-232 Communication Protocol RS Port v.1.61	35
3.7.1 Introduction	35
3.7.2 General Frame Format	35
3.7.3 Used Frames	36
3.7.4 Frames	37
A. Frames from the host to the controller	37
B. Frames from the controller to the host	41
3.8 Examples	47
3.8.1 CRC Calculation	47
3.8.2 Initialization	48
3.8.3 Measure	48
Appendix:	49
AG 1024 Specifications	50

INTRODUCTION

The T&C Power Conversion, Inc. Model AG 1024 Amplifier Generator is a totally solid state, air cooled RF power source expressly designed for use in general ultrasonic and gas plasma applications. The amplifier/generator utilizes conservatively rated solid state components and automatic power control circuitry to ensure reliable and continuous performance. Completely self-contained, the AG 1024 provides all of the control and monitoring functions needed in a state-of-the-art power amplifier/generator, which will provide up to 1800 W continuous output (up to 2000 W in pulsing) into a 50 Ohm load.

The AG 1024 measures forward power, reflected power, and the current draw of its power amplifier module. Should any of these parameters exceed a preset limit, the power control circuit will immediately limit the amplifier/generator's RF power output so that the components always remain within safe operating limits.

The AG 1024 is equipped with two types of remote control interface. The standard T&C Power Conversion, Inc. Analog Interface (see pages 27-28) allows control and monitoring of the amplifier/generator through the use of Analog voltage control signals. The RS-232 Digital Interface (see page 28) allows control and monitoring of the amplifier/generator through the use of PC Windows operated GUI Software, or custom RS-232 set of commands (see page 35). Both Digital and Analog Interfaces provide full control of the unit and allow for automated operation through the use of computers on these ports.

The AG 1024 can accommodate a wide range of AC line voltages automatically.

Only minimum maintenance is required to guarantee successful operation and endurance of your AG 1024 amplifier/generator. The unit's completely solid state design substantially reduces DC voltages which eliminates the hazards associated with servicing high-voltage vacuum tube equipment.

The AG 1024 is classified as ISM (Industrial/Scientific/Medical) type of an equipment.

This manual is divided into three chapters and an appendix. Please refer to the following descriptions to help you locate the information you need.

Chapter	
1	Deals with precautionary details. Please read this if you are unfamiliar with the AG 1024 or T&C Power Conversion's warranty procedures
2	Explains how to install and power up the system for the first time
3	Describes the operating details of the AG 1024
Appendix	Technical Specifications

1.1 Labels

Labels are provided to alert operating and service personnel to conditions that may cause personal injury or damage to the equipment from misuse or abuse. Please read the labels and understand their meaning.

1.1.1 Important Operating or Maintenance Caution



Definition: Attention, consult accompanying document

The exclamation point within a triangle is to alert the user, operator or service personnel to the presence of important operating and/or maintenance instructions in the User's Manual.

1.1.2 Shock Hazard Warning



Definition: Caution, risk of electric shock

The lightning bolt within a triangle is to alert the user, operator or service personnel to the presence of unprotected voltage points within the enclosure of sufficient magnitude to cause dangerous electric shock.

Only authorized service personnel with the schematic diagram and knowledge of the voltages within the equipment shall remove covers or panels bearing this symbol.

1.1.3 Caution Warning

Do not operate this amplifier with the cover removed. Lethal voltages are present beneath the cover. The cover protects against **electrical shock** due to AC line voltage, high RF potential in the hundreds of Volts at the output transformer, coupler and output connections. Also the DC supplies produce high voltages in the conversion process and are capable of producing more than 25 Amps of current at nominal output voltage. The cover is an integral part of the air ducting system that keeps components cool. Without the cover in place, insufficient air flows between and around the two DC power supplies causing overheating of the internal components.

Always connect the load to the RF output connector before connecting the RF input to the amplifier. This will ensure that high voltage at the center pin of the output BNC connector will not be exposed. Take care not to interchange the input and output cables.

Chassis Terminal

Be sure the chassis is grounded to a reliable earth ground using the grounding stud provided on the rear panel. In addition, be sure the grounding wire remains connected securely between the cover of the chassis and the base of the chassis.

1.1.4 AC INPUT – Alternating current input.

The AG 1024 is configured at the factory for one of the following voltage ranges, based on the destination country. Refer to the chart on page 18 and the marking on the rear panel before connecting to supply.

2/N/PE ~ 208-240 V, 35 A, 50-60 Hz

2/N/PE ~ 200V, 42 A, 50-60 Hz

2/N/PE ~ 346-415 V, 16 A, 50-60 Hz

Chassis Terminal — For connection of AG 1024 to a proper safety ground.

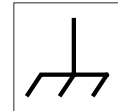

1.1.5 External RF IN

Definition: RF Input

The External RF IN symbol is to identify the signal input port for the user, operator or service personnel.

1.1.6 RF OUT

Definition: RF Output



CAUTION!

RF Output voltage up to 900 V p-p,
From 0.02 to 3 MHz may be present
At this amplifier output!

**Take precaution. Do NOT touch connector
When operating!**

The RF Out symbol is to identify the signal output port for the user, operator or service personnel.

1.1.7 EDITOR – Frequency or power adjustment in EDIT function.

When POWER: gain adjustment IN MGC Mode, Output Level Adjust in AGC Mode.

When FREQUENCY: frequency setting of INTERNAL signal source. 1kHz resolution.

Definition: gain value or output power level knob for:

Power Entries: when EDIT selector in POWER position

Frequency Entries: when EDIT selector in FREQ position.

1.1.8 Miscellaneous Symbols

AC Power Switch



AC Power Off Symbol

Figure 3

Definition: Off (power: disconnection from the AC mains)

The Off symbol on the AC Power Switch is to identify the functional configuration of the toggle switch (when the switch handle is pointing towards “AC OFF”) for the user, operator or service personnel.



AC Power On Symbol

Figure 4

Definition: On (power: connection to the AC mains)

The On symbol, next to the AC Power Switch is to identify the functional configuration of the toggle switch (when the switch handle is pointing towards “AC ON”) for the user, operator or service personnel.

1.1.9 Service

T&C POWER CONVERSION, INC. is responsible for safety and performance of the equipment only if:



- Assembly operations, extensions, readjustments, modifications, or repairs are carried out by authorised personnel.



- The electrical installation is made in accordance with User’s Manual and the room in which the equipment is installed complies with the environmental requirements,
- The equipment is used strictly in accordance with the instructions in this manual or associated test documents.

1.1.10 Name plate

The AG 1024 can be identified by a name plate on its rear side panel that contains the following information.

Figure 5 Name plate

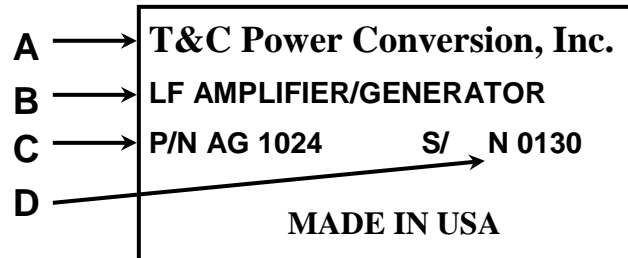

A. MANUFACTURER

T&C POWER CONVERSION, INC
110 Halstead Street, Suite #7
Rochester, NY 14610
USA

B. TYPE OF EQUIPMENT

This line holds the description of what the equipment is intended to be used for.

C. MODEL NUMBER

The assembly number which uniquely identifies product configuration is entered on this line.

D. S/N

This line contains a number which is sequentially assigned as the product is manufactured.

System Installation



Note: Chapter 2 is for "Authorized Personnel" only, qualified in electrical installation

2.1 Initial Installation

2.1.1 Mechanical Inspection

If damage to the shipping box is evident, request the carrier's agent be present when the unit is unpacked. Check for equipment damage and inspect the cabinet and panels for dents and scratches.

2.1.2 Claim for Damage

Please notify T&C Power Conversion, Inc. directly or your authorized T&C representative if the product is mechanically damaged or fails to meet specifications upon receipt. Retain the shipping box and packing material for the carrier's inspection as well as for subsequent use to return the unit should this become necessary.

2.1.3 Packaging for Reshipment

Whenever possible, the original shipping box and packing material should be used for reshipment. If the original packing material is not available, wrap the instrument in heavy paper or plastic. Use a strong shipping container.

Use shock-absorbing material around all sides of the instrument to provide a firm cushion and to prevent movement inside the container wall on each side. Protect the front panel by means of cardboard spacers inserted between the front panel and the shipping box. Make sure that the instrument cannot move in the container during shipping. Mark the container:

FRAGILE DELICATE INSTRUMENTS

2.2 Installation Requirements

The AG 1024 is designed for stand-alone or system installed operation. To guarantee the best performance, make sure there is adequate clearance for the entrance of cooling air to the front of the unit as well as for the exhaust out the back of the unit. (12" min.)

The AG 1024 is of modular design, consisting of four (4) Power Amplifier Modules (PAM). Each module consists of a 1.1kW Switch Mode Power Supply (SMPS), 600W Radio Frequency Power Amplifier (RFPA) and cooling fan.

The AG 1024 may be connected to any of the following electrical distribution systems.

Region	Voltage	Frequency	Phase Requirements	Minimum Branch Circuit
North America (US, Canada & Mexico)	120/208 V ac or 120/240 V ac or 127/220 V ac	50-60 Hz	2 Lines / Neutral / Safety Ground	35 A
Japan	100/200 V ac	50-60 Hz	2 Lines / Neutral / Safety Ground	42 A
International	200/346 V ac or 220/380 V ac or 230/400 V ac or 240/415 V ac	50-60 Hz	2 Lines / Neutral / Safety Ground	16 A

Unit does not require any special internal adjustments if operated within the specified voltage range. Please refer to following diagrams that outline alternate AC connections based on locally available AC Line voltage.

The Mains Plug is considered the product's main disconnect. The AC power outlet must be located within 10 ft (3 m) and is readily accessible to the user.

Please check the following items before applying AC power to the AG 1024:

- Check Unit for any physical damage that could affect safety.
- Insure that a proper outlet is selected in consideration of the voltage and current requirements outlined above.
- Connect AG 1024 chassis to a proper safety ground. (Use Grounding Stud on rear panel) A green insulated 8-gauge wire or heavier, less than 50 foot in length, is recommended.

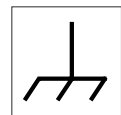

North American Configuration

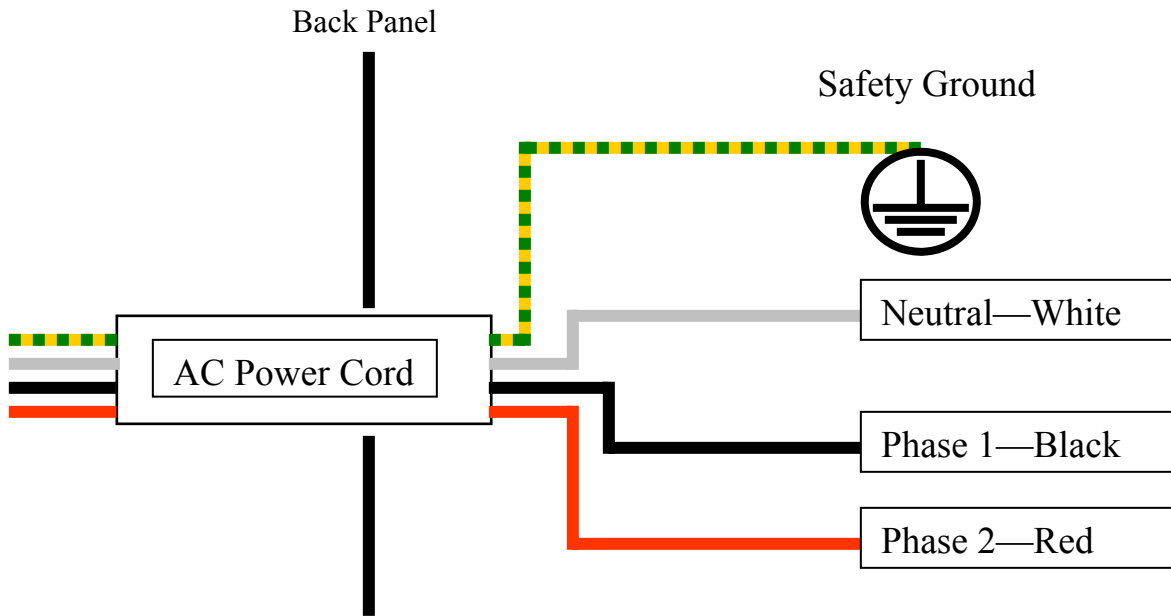

International Configuration

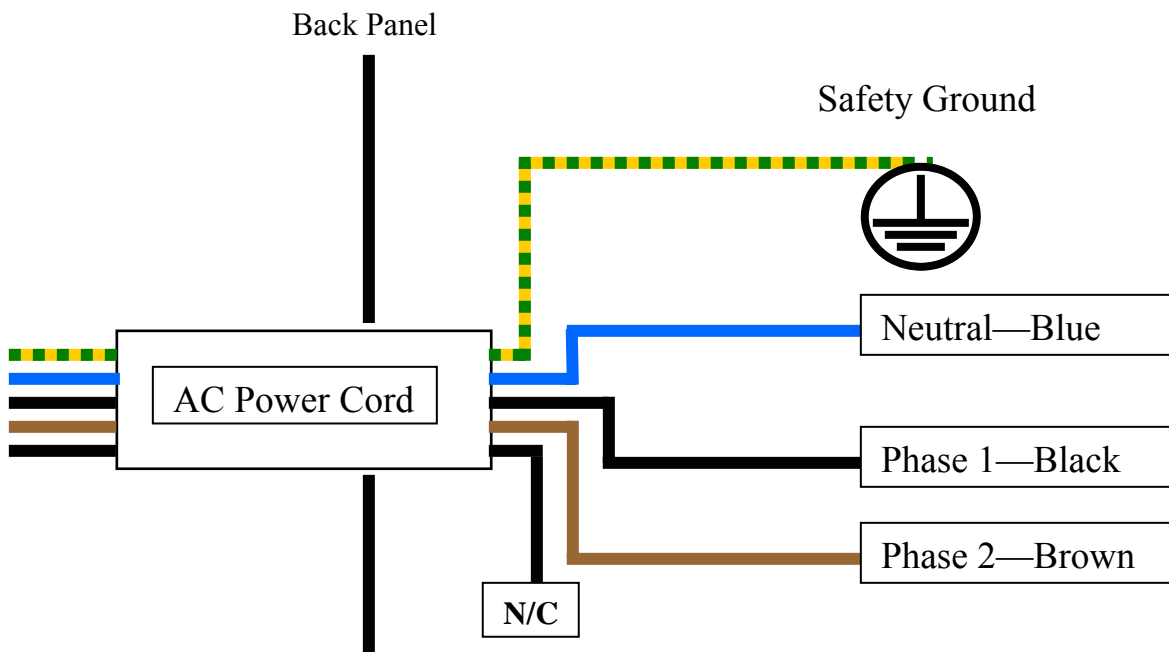

- This page intentionally left blank -

2.3 Cooling and Ventilation

The AG 1024 is protected against damage caused by lack of air flow. If inadequate air flow causes the temperature to rise over the OVERHEAT threshold, the amplifier/generator senses and OVERHEAT fault, and RF power is automatically shut off. RF power will be restored automatically after the temperature falls below threshold.

For proper ventilation, adequate clearance of at least 6 inches (~150 mm) should be provided for the cool air intake on the front panel of the amplifier/generator. The ports located on the rear panel of the unit, should have at least 6 inches (~150 mm) of clearance and also be free from obstruction. To reduce potential overheating, do not allow exhausted warm air from the back to re-circulate to the front of the unit.

Maximum Ambient Temperature: 40°C

2.4 Power Line Voltage

The AG 1024 is rated as indicated below. It may be connected to any of the electrical distribution systems shown on page 18.

<p>2/N/PE ~ 208-240 V, 35 A, 50-60 Hz</p> <p>2/N/PE ~ 200V, 42 A, 50-60 Hz</p> <p>2/N/PE ~ 346-415 V, 16 A, 50-60 Hz</p>

2.5 System Interconnection

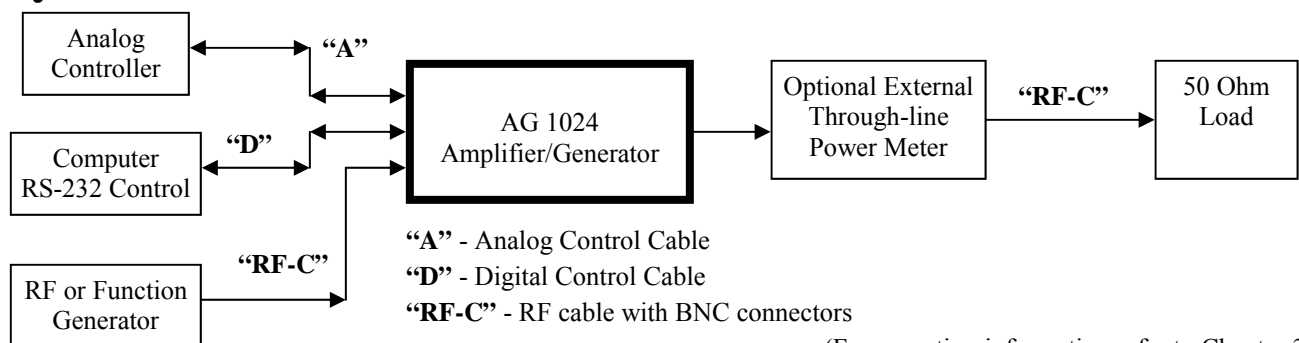

(For operation information refer to Chapter 3)

2.6 Initial Turn-On Procedure

The following procedure outlines a simple test to check for proper operation of the AG 1024 amplifier/generator. It is assumed that the amplifier/generator is already connected to an appropriate AC power source, and a suitable (>2000W) 50 Ohm dummy load (as indicated in the diagram above).

Turn ON the main AC switch from the front panel.

1. The screen should flash the name of the manufacturer, serial number, and software version before displaying the PMi (Power Mode Internal) function.
2. Check all the LED switches. Each switch contains two functions, when activated (marked ☀) the appropriate switch should light up.

Screen Displays:

Switch	function	screen
RF Output	☀ON	PMi=0.0%G FP=0W LP= 0W RP=0W
	OFF	PMi= 0.0%G RF OFF
Edit	☀Freq	F= 1.000MHz RF OFF
	Power	PMi= 0.0%G RF OFF
Mode	☀AGC	PAi= 0W RF OFF
	MGC	PMi= 0.0%G RF OFF
Source	☀EXT	PMe= 0.0%G RF OFF *
	INT	PMi= 0.0%G RF OFF *

* in MGC Mode

3. **Run a test.** Activate the RF Output ☀ON function and increase the PMi percentage to 50%. The FP reading should be approximately 800W. Next increase the PMi to 100%. The FP reading should now read approximately 1700W-1900W (depends on the temperature).

4. Set the PMi back to 0%. With the RF Output ☀ON function still activated, press the Mode LED switch for the AGC function. Verify that the PAi, FP, and LP reading are the same. Increase PAi to 2000W. Make sure that the FP and LP read 2000W and are flashing. This indicates the maximum limit. Reduce PAi to 1900W, and flashing should stop.

5. Decrease PAi to zero. Disconnect RF output, and increase the PAi to 400W. FP should equal 400W. LP and RP should be flashing. LP will equal 0W (readings of up to 5W possible) and RP will equal 400W. When reducing below 400W, the flashing should stop.

6. Reduce PAi to zero, and reconnect load.

7. This concludes the test. The unit is operating properly and ready for use.

Operation

The *AG 1024* is a bench top mounted laboratory amplifier/generator with expressive front panel features. On the left end of the front panel is the **AC line** power ON / OFF switch. This heavy-duty double pole circuit breaker connects and disconnects the hot and neutral power line connections. The power supply switches automatically to the line voltage applied to the unit.

The lit up LCD display shows that AC power is connected to the unit, the power switch is on and the DC power is available to the amplifier. The amplifier has Type “**BNC**” RF coaxial connector on the rear panel for easy connection of the signal source and type “**N**” connector for the load. The user must assure that connecting cable to the output is of the 50-Ohm type. Cables of other types may introduce a mismatch that will reflect power back into the AG 1024.

Forward RF power is continuously measured and indicated on the forward power (FP), the upper right quadrant of the display. Reverse reflected power (RP) is similarly displayed on the lower right quadrant of the display. In normal operation, the forward power is at maximum gain in relation to the drive signal applied to the input, while the reverse power is a relatively small portion of the forward power. Few loads are a perfect 50 Ohms, so some reflected power is typical. The opposite extreme, a faulty load (either open or shorted), results in significant reflected power typically near the level of the forward power. The continuous and highly visible real time, simultaneous display of forward, reflected, and load power (LP) is of great benefit in monitoring a RF power delivery system, that this product offers.

The air intake must be kept clear of obstructions. A wide area of ventilating holes serve as the air intake for ventilating the amplifier. *The air intake must be kept clear of obstructions*, as should the fan outflow at the rear of the unit. Allow a minimum of 12” clearance around all sides of the chassis. The fan’s speed is proportional to the temperature rise of the internal heat sink. There is also a high temperature cut out switch that shuts down the amplifier if the heatsink gets too hot. This could happen; for example, if the intake airflow is obstructed. RF power will be restored automatically after the temperature falls below threshold in the case of PA is overheated; activate RF Out when power supply is overheated.

3.1 Front Panel Controls and Display:

There are four amber buttons, beneath the display, that illuminate when selected. These are used in conjunction with the “**EDITOR**” knob and the display to provide manual control. Four buttons are labeled **RF**, **Edit**, **Mode**, and **Source**. We will discuss each button’s purpose and operation, from left to right. The buttons will retain their default settings: RF–Off, Edit – Power adjusts with EDITOR knob, Mode – MGC, Source – INT (internal default 0.5MHz).

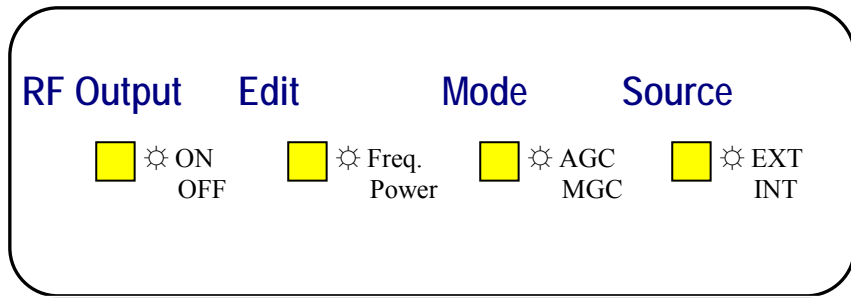

RF Output: RF Output will default to off each time unit is turned on. RF Output button will not illuminate and the display will show in the upper right quadrant as RF OFF.

☀️ Pressing the switch will cause it to illuminate and RF output will be active depending on the settings of Edit, Mode, and Source. The RF Output switch must be pushed to illuminate the switch and allow the unit to operate.

WHEN PULSING IN BURST MODE, the unit will not switch to AGC. In addition, when using AGC mode the unit will not allow you to switch to Burst mode.

Edit: Edit will default to power setting when AC is turned on. The edit button will not illuminate, and the display will indicate the power settings accepted by the EDITOR knob. The display will show in the upper left quadrant as PAi = XXXX W or PMi = 0.0%G

☀️ When illuminated, the display will indicate the frequency settings accepted by the EDITOR knob. In Edit Power the display will show F = X.XXX MHz when Editing Frequency.

Mode: Mode will retain the last setting used before the unit was switched off.

☀️ **AGC** (when illuminated) - Automatic Gain Control. Power output controlled by EDITOR knob and pin 5 of the remote Analog DB25 Connector (scale 1 VDC = 250 Watts) or by settings from personal computer control window of Graphic User Interface (GUI) via RS 232 communication connector.

MGC (when not illuminated) - Manual Gain Control. The EDITOR knob will control the output power. In MGC, internal fixed gain control may be set from close to 0 W (0.0%G) to full gain of 63dBm (100.0%G) by the EDITOR knob. MGC “%G” scale is not linear. Read Forward Power level for desired value when adjusting the EDITOR knob.

Source: Source will retain the last setting used before the unit was switched off.

☀️ External signal source when illuminated. Requires a signal input to the RF input connector on the back panel. The signal will be amplified as noted in the specification.

Internal signal source when not illuminated. This will cause the unit to be operated as a RF Generator. The EDITOR knob will adjust the digit that is selected.

EDITOR knob:

- When in MGC (Edit – Power) is selected, EDITOR is used to select the power by varying internal fixed gain setting.
- When in AGC (Edit – Power) is selected, EDITOR is used to select the power by varying internal gain setting to accomplish desired constant output power. By depressing the knob quickly, it toggles the adjustment option from units to tens of Watts.
- When the internal signal source is selected (Source: INT, Edit – Freq.), this adjustment is used to select the frequency. By depressing the knob, a cursor will toggle through the selection of units, from 1kilohertz to 100’s of kilohertz on the frequency display. The knob is then rotated to select the digit preferred for that position.

3.2 Rear Panel:

The female 25 pin D-style connector is for remote monitoring and control. A label describes the pin functions assigned to the connector. Additional details are provided on page 27 and 28.

NOTE: When this method of control is used, it has priority over all other methods.

The female 9 pin D-style connector is for the RS-232 interface. Complete information is in the related tables on pages 28 and 35 to 48.

NOTE: When RS-232 control is in effect, it shares control and information with the front panel adjustments and displays.

Burst and Sweeping:

AG 1024 offers three modes of operation: External Burst, Internal Burst, and Sweep. For more information about the graphic user interface GUI, see page's 29-34 of this manual.

External Burst mode can be activated one of two ways. Either by applying 5Vdc to pin 16 of the DB-25 connector, or by using the RS232 communication port with GUI (RS232 Port V.1.61 Protocol) and selecting External Burst Mode under options/ Burst & Sweep. With External Burst Mode active, a TTL signal with a specific pulse time and width, can be applied to pin 15 of the DB-25 connector. When using this mode, remember that if the Burst mode is requested using the GUI, It will default to off when unit is switched off. However, if 5Vdc is applied to pin 16, the burst mode will be active when unit is switched on/off until the voltage is removed from pin 16.

Internal Burst Parameters and Sweep Parameters can be activated only by using the GUI. The option is located under Options/ Burst & Sweep. More information located can be found on page 34.

Interlocking features for RS-232 requires, that the AG unit and computer interface are connected and remain connected, or RF ON power will be interrupted.

NOTE: this feature is optional - please request controller software with active RS232 Watchdog.

3.3 Remote Control:

Description: These additional features are provided by use of the Remote Control:

- *Power Leveling within + / - 0.5 dB. From 20 kHz to 3 MHz min.*
- *Remote power level adjustment and control.*
- *Remote access to forward and reverse power level information.*
- *Status flags indicating power on, thermal limit, reverse power limit.*

Operation: To enable remote operation, the remote control signal must be asserted (+5 Volts) at pin 8 of the rear panel connector. To remotely control the amplifier's power level, pin 5 must be provided with a DC voltage proportional to the RF power level desired. Refer to the table of panel connector pin descriptions on page 25 of this manual.

Under remote control, the final output power level is still partly dependent upon the drive level provided to the front panel input connector. This is necessary due to the finite power gain of the amplifier. In most applications it is desirable to start with a drive level in local control that produces half the maximum power that may be desired under remote control. This ensures that there is sufficient drive at the amplifiers input for remote control to attain the full range of remotely set power. For example, to be able to vary the output power level from zero to 50 Watts remotely, the drive level could be started from – 16 dBm. This is demonstrated as follows: A power of 100 Watts is 50 dBm. Half of that power is 47 dBm (50 Watts), subtracting the amplifier's gain (63 dB) yields an input power level of – 16 dBm.

The preceding discussion provides a good starting point though any output power level can be reached with different combinations of input drive level and remote power control voltage. In applications where minimum signal distortion is of special importance, the combination may be altered. This is particularly useful in fixed frequency applications. Optimal levels for frequency swept use are best judged empirically.

The rear panel connector's socket pins are numbered 1 to 13 reading from right to left across the top row. Returning to the right, the bottom row is 14 to 25.

A simple test circuit for remote power adjustment uses a multiturn 10 K potentiometer wired as follows: CCW terminal to pin 12 (AGND), CW terminal to (+5 Volts) and pin 8 (EXT. CONT. SEL.), and the wiper of the pot connected to pin 5 (RF control input).

Blanking and Pulsing: The connector also has a blanking input on Pin 14. A TTL High level on Pin 14 in relation to Pin 18, 19, 21 (Analog Ground) will interrupt the RF Output. The normal open condition allows normal operation. Pulsing can be accomplished by maintaining a positive TTL level on Pin 14 and pulsing it to ground and back to positive. The RF Output will then pulse in relationship to that DC pulse. Please contact the factory for special applications and uses.

NOTE: Pin 14 must never go negative in relation to Pin 18, 19, 21.

NOTE: Unit must be in MGC mode.

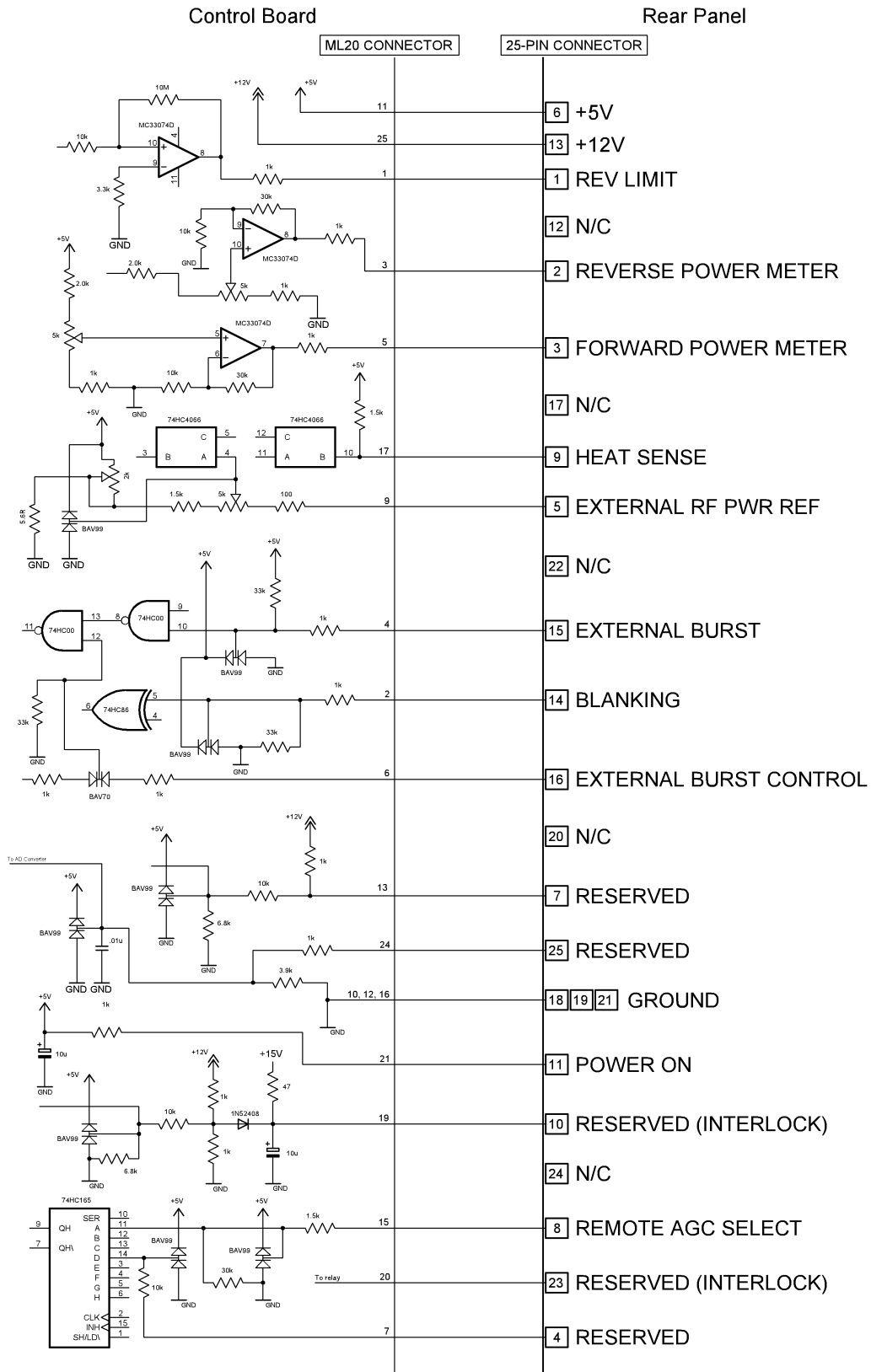

25-pin Analog Remote Interface Schematic

3.4 Rear Panel Connector, Analog DB-25 Option:

Pin #	Name of Signal	Signal Description
1	REV LIMIT - This output indicates that output power level was automatically reduced under load mismatch conditions.	TTL Compatible; Hi = RF Out Limit, Lo = Normal operating condition at low VSWR. Signal Direction: OUT
2	REVERSE POWER	Linear voltage output, 1 Vdc = 250W scale Signal Direction: OUT
3	FORWARD POWER	Linear voltage output, 1 Vdc = 250W scale Signal Direction: OUT
5	EXTERNAL RF PWR REF - optional part of AGC	Linear voltage input, 1 Vdc = 250W scale Signal Direction: IN
8	REMOTE AGC SELECT	TTL Compatible; Hi = remote control active, Lo = remote control disabled, Signal Direction: IN
9	HEAT SENSE - This output indicates that the unit has become too hot.	TTL Compatible; Hi = FAULT/Amp disable, Lo = amplifier enabled Signal Direction: OUT
10, 23	INTERLOCK - optional on special request.	CONNECTED: amplifier enabled OPEN: amplifier disabled Signal Direction: IN
11	POWER ON: DC power applied to control circuit; indirect meaning AC is ON.	TTL Compatible; HI = Power ON, Lo = Power OFF Signal Direction: OUT
14	BLANKING SIGNAL	TTL Compatible; HI = interrupts RF at output connector, Lo = uninterrupted operation. Signal Direction: IN
15	EXTERNAL BURST - Defines Pulse Time and Width input.	TTL compatible input: HI - BURST RF OUTPUT LOW - BURST RF OFF
16	EXTERNAL BURST CONTROL	TTL compatible input: HI - RF EXTERNAL BURST READY LOW - NO SIGNAL OR BURST OFF
18, 19, 21	ANALOG GROUND (BLANKING AND BURST RETURN)	Return for pin 14, 15 and 16

3.4.1 Rear Panel SubD9 RS232 I/O Connector Signal Description Table

Pin #	Name of Signal	Signal Description
2	RxD Data from Controller to PC	RS 232 signals Signal Direction: OUT
3	TxD Data from PC to Controller	RS 232 signals Signal Direction: IN
5	GND	Signal Common GND Signal Direction: IN/OUT
1, 6, 7	Quasi HANDSHAKING for PC	Pins shorted on Controller side Signal Direction: OUT
4, 8	Quasi HANDSHAKING for PC	Pins shorted on Controller side Signal Direction: OUT

3.5 Graphic User Interface, GUI OPERATION

Connect cable from Comm port of computer to RS-232 connector on rear of unit. Power ON computer and load T&C supplied software in disk drive. (Program may be transferred to hard drive). Access Disk and run program.

AG UNIT Power on and Install program: RUN:/C:/folder name/ TCCP.exe The program will be displayed as below.

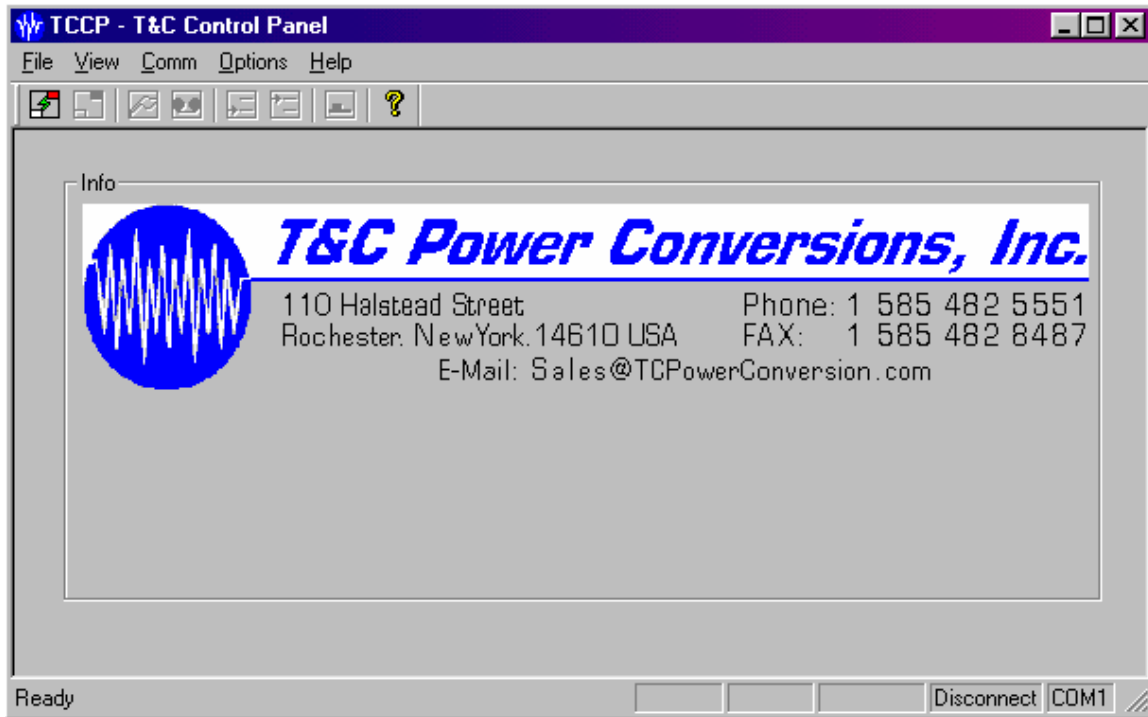

Select proper Comm port for your PC (Select COMM, then select proper port). Display 1.1 shows actual amplifier operation and settings. When the unit is first turned on the normal mode of operation is Manual Gain Control MGC (fixed gain set by % scale).

Apply RF signal to input connector. The signal should be from -20 dBm to 0dBm (0dBm for AGC operation) and within the frequency range of the unit. **CAUTION: There will be an output. The amplifier should be terminated into a load before signal is applied.**

Interlocking features for RS-232 requires, that the AG unit and computer interface are connected and remain connected, or RF ON power will be interrupted

NOTE: this feature is optional - please request controller software with active RS232 Watchdog.

When pin 8 of the DB-25 connector is activated with a TTL-Hi signal, the DB-25 connection takes priority over both the RS-232 Remote Control (GUI), and the Front Panel Controls.

3.5.1 GUI PROGRAM FOR RS 232 INTERFACE

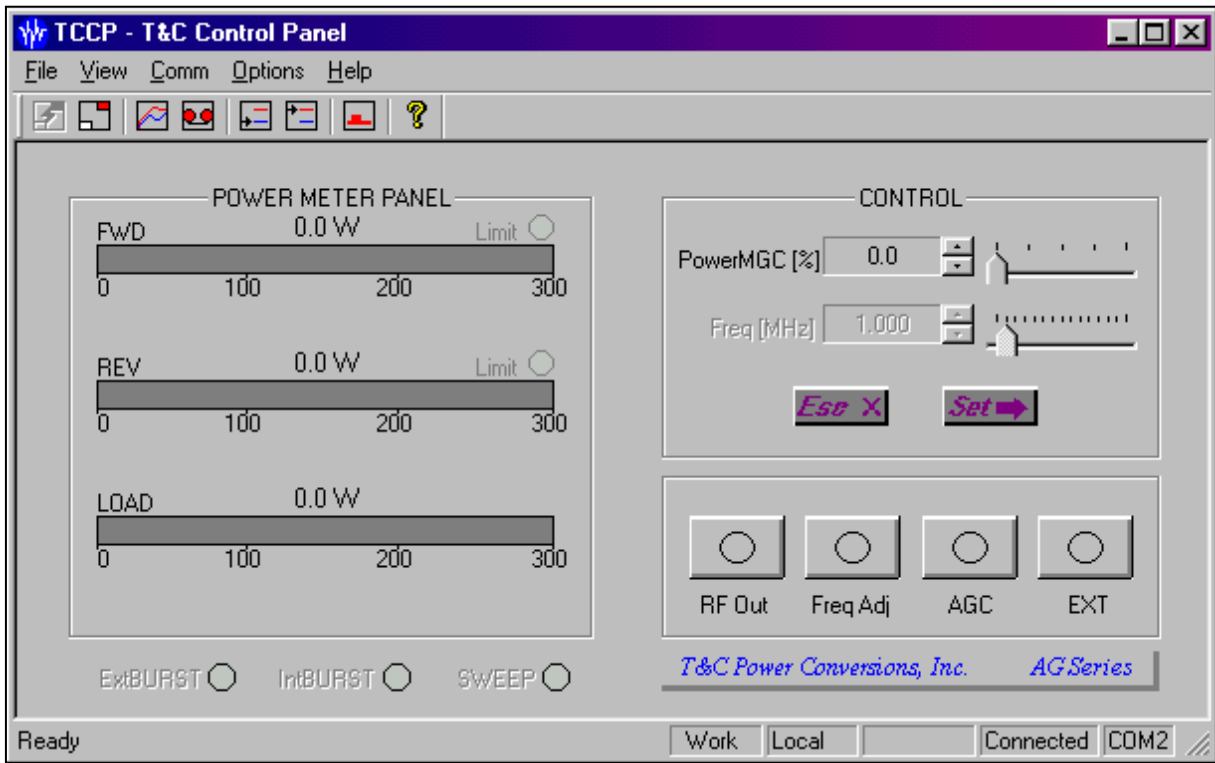

The icons on the toolbar here are short cuts to the menu above it. The toolbar can be enabled or disabled through the view tab.

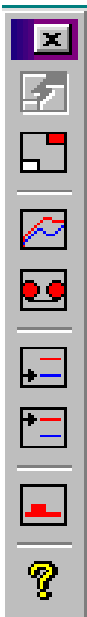
<p>CONNECT</p> <p>DISCONNECT</p> <p>WAVEFORM</p> <p>RECORDER</p> <p>SETTINGS</p> <p>LIMITS</p> <p>BURST & SWEEP</p> <p>REVISION</p>		<p>when not connected icon appears</p> <p>will disconnect computer from unit</p> <p>to switch between bar form and wave form</p> <p>stores power level over selected time frame</p> <p>sets the TCCP Program Settings and the limits</p> <p>opens menu for external burst, internal burst parameters, and sweep function.</p>
---	---	---

3.5.2 WORKING GUI AND ACTIVE UNIT

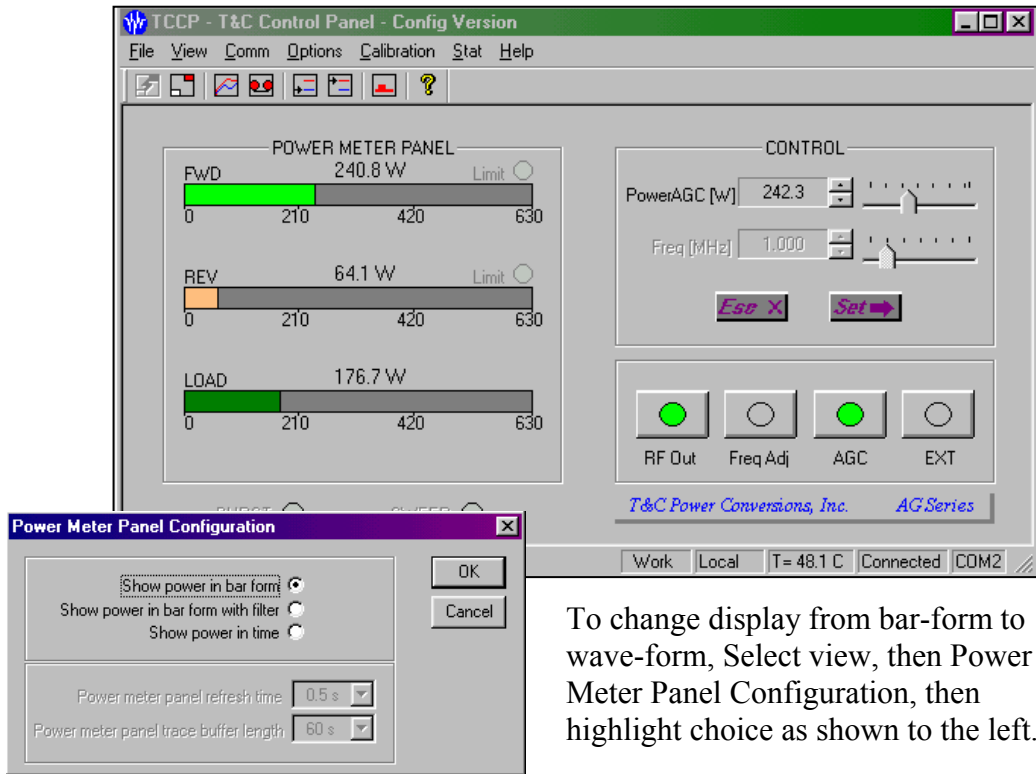

To change display from bar-form to wave-form, Select view, then Power Meter Panel Configuration, then highlight choice as shown to the left.

The above display shows power readings of forward (FWD) reverse (REV), and load power. The unit is working in Automatic Gain Control and under a 3:1 load, or 17 ohms resistive.

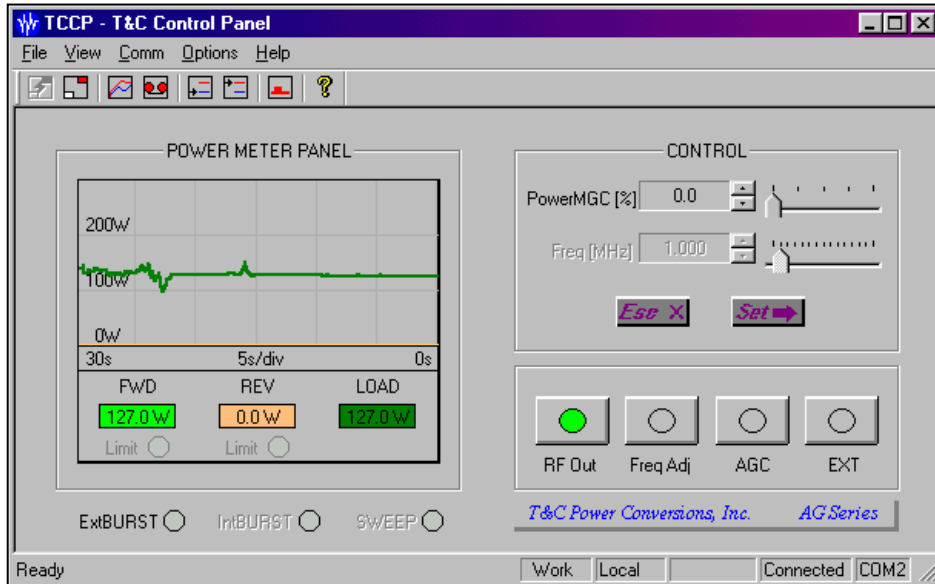

The above display is an example of power in time. Using the power meter panel configuration, the duration of power shown and refresh time can be adjusted. In this example, the panel shows the last 30 seconds and has a refresh rate of 0.5 seconds. The user can define time duration of 10 to 60 seconds and a refresh rate of 0.5 to 2 seconds.

3.6 INDICATORS



The illuminated button indicates that the option is active. To activate the options simply select with pointer. Multiple options can be active at the same time.

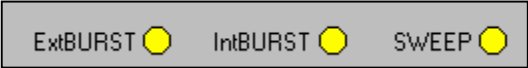

The burst and sweep function is activated using either the menu or shortcut icon. When the function is active the indicators will activate,



The limits are located above the power level bar, and will illuminate when the limits are reached. This is only an indication of maximum level reached.

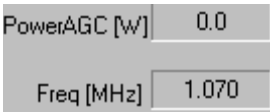

The readings in the open box displays what the current level is when "Set" is selected, when the Esc and Set buttons are blue the values are being edited.

The bottom of the screen contains information such as Working or Over-Heat, Temperature inside unit, Connection status, and Communication port.

3.6.1 CONTROLS

The box labeled "CONTROL" has two ways of adjustment, either the slide bar or the up/down arrows. This box is used for Automatic Gain Control (W), Manual Gain Control (%), and/or internal frequency generation (MHz).

This option will become active when the values are adjusted and the Set button is selected. Another option to enter values is described below in section 2.3.



The button is used to choose which method of power generation or amplification to be used. It is possible to use all buttons together and several functions at the same time, such as AGC or MGC and Internal or External frequency. Under some conditions it is important note what option is active, for example:

In the condition when an External source is driving the unit, it is possible to adjust and Set the internal frequency with out interrupting the current signal externally applied. Then when EXT is selected the unit will immediately switch to the internal source and the frequency Set previously applied.

CAUTION: If you are operating unit at 100% in External source, and your source driving the unit is -5dBm or less, when EXT is switched off, The unit will produce full power (100%) in internal source mode. Also note the levels when switching between AGC and MGC. It is possible to set MGC to 50%(800W) and AGC to full power (2000W), there for it is important to remember what the previous settings were before switching. If there is any doubt, select the RF button to turn RF power off and check values.

3.6.2 OPTIONS

The Options tab has the same selections as the toolbar. The following is a summary of each choice.

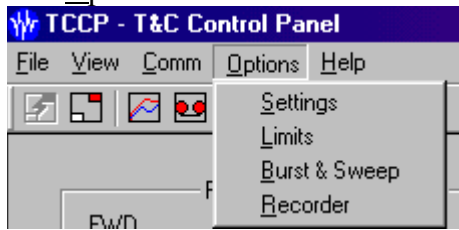

SETTINGS

Settings are used in the same way as the control panel except the values can be entered manually with the keyboard and both AGC and MGC can be "set" at the same time. This may be useful if the application requires switching between AGC and MGC mode.

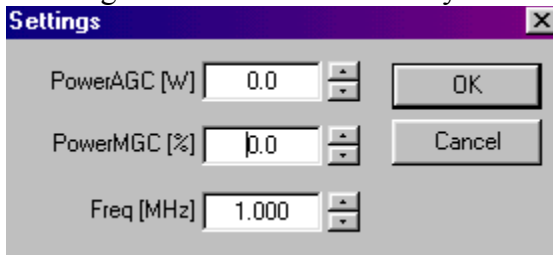

LIMITS

Limits allow the user to define the limit to be used up to the maximum default value. The AG unit has a maximum allowable power limit settings which prevents damage to the unit. The user can set any value below the default.

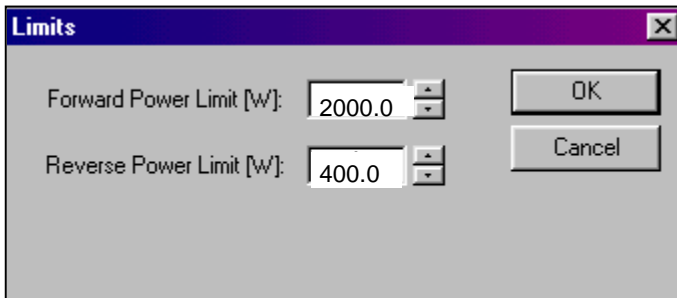

In applications where it is important to keep power levels below a specific maximum, the limit settings will be very helpful.

When settings or limits are used, and the AG unit or GUI is shut down all settings and limits will revert to the default settings.



BURST & SWEEP

The burst & sweep option has choices such as External Burst, Burst Parameters, and Sweep parameters.

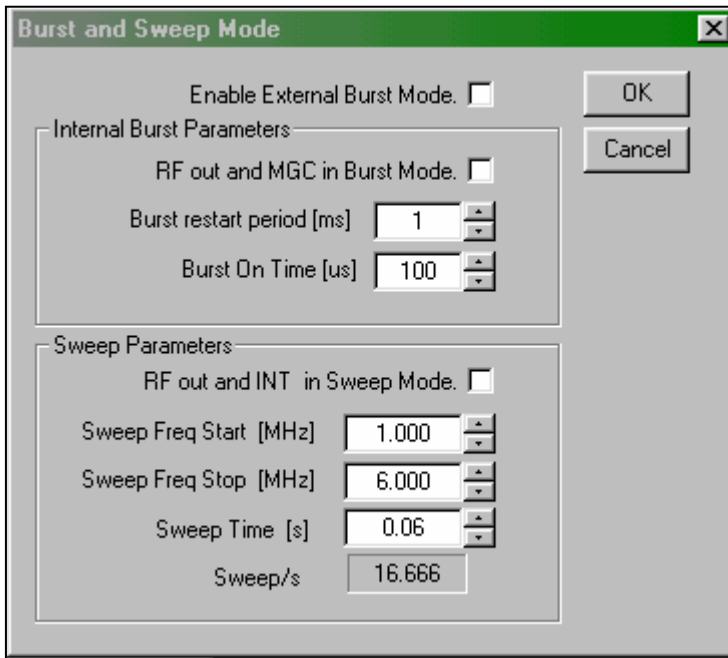

When **External burst** is chosen a TTL signal with a specific pulse time, and width can be applied to pin 15 of the DB-25 connector.

The external burst option can be enabled by applying a TTL compatible HI to pin 16 as well. The maximum delay time between the TTL pulse and the output pulses produced is 5uSec.

When **Burst parameter** is chosen, the unit will automatically switch to MGC mode. The internal burst function allows for 1-50uSec. Pulse time and 1-500mSec. Pulse width.

When **sweep parameter** is used, the unit switches to its internal frequency generator and will sweep from Sweep Frequency Start (20 kHz) to Sweep Frequency Stop (3MHz) in a time of .01 seconds to 10 seconds.



RECORDER or store measure.

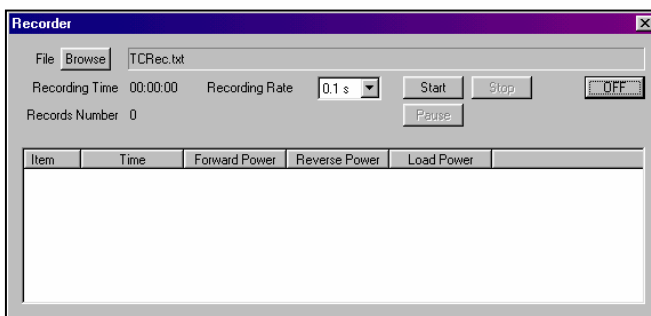

The recorder will save measurements similar to the display in notepad. This option can be set to record from a time interval of 0.1 to 2 seconds between measurements. It will begin measuring the forward, reverse and load power immediately after **start** is pressed, and can be paused any time during the measurements. The measured values can be

viewed in notepad after the measurements are complete and stop is pressed.

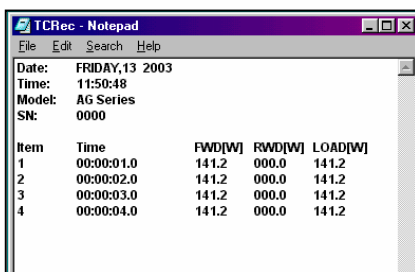

This is an example of measurements that have been sent to notepad. The recorder will use the same file each time, there for to retain information each time, the user must either save the notepad file under a different name or change the file to be used with the file "browse" selection on the recorder.

The file to be used must have a .TXT extension.

3.7 RS-232 Communication Protocol RSPort V.1.61

3.7.1 Introduction

Communication between HOST (ex. PC) and the amplifier controller uses asynchronous transmission protocol. Setup of the communication port should look like the example:

Bits per second	19.200
Data bits	8
Parity	NONE
Stop bit	1
Flow controls	NONE

Host and controller exchange information in frames form. The polling protocol is used for communication. The host is working as a master, controller as a slave. The host has to initiate transaction sending command frame to controller. Then the controller executes the command and sends a response to the host. The controller never initiates a transaction, it only sends one frame for a command from the host. If the host sends an incorrect frame, the controller will send a frame REJ.

3.7.2 General frames format

Frame consists of five fields:

<i>Field</i>	<i>Length</i>	<i>Function</i>
HEAD	1 byte	Header of frame=96H
LEN	1 byte	Length of frame: number of bytes in fields:<CTRL, DATA, CRC>
CTRL	1 byte	Command code
DATA	<0 , 12> bytes	Command parameters
CRC	1 byte	The control sum. The generator polynomial is $x^8+x^5+x^4+1$. CRC is counting from fields = HEAD, LEN, CTRL, DATA, CRC.

The frame is variable in length, number of bytes in a frame are between 4 and 16.

3.7.3 Used frames

Figure 3.1

HOST TO CONTROLLER			
Mnemonic	CTRL	LEN	Description
SetLIMITS	2	10	Set Limits.
SetPAGC	3	4	Set power level for AGC mode.
SetPMGC	4	4	Set power level for MGC mode.
SetFREQ	5	6	Set frequency.
SetSKEY	7	3	Set soft key.
SetBurstPar	8	7	Set burst parameters.
SetSweepPar	9	13	Set sweep parameters.
GetLIMITS	18	2	Get Limits.
GetPAGC	19	2	Get power level for AGC mode.
GetPMGC	20	2	Get power level for MGC mode.
GetFREQ	21	2	Get frequency.
GetSKEY	23	3	Get soft key.
GetBurstPar	24	2	Get burst parameters.
GetSweepPar	25	2	Get sweep parameters.
GetSVER	29	2	Get controller Soft/Hard version.
GetMEAS	30	2	Get measurements.
GetSTA	31	2	Get status.
CONTROLLER TO HOST			
ShowLIMITS	2	10	Show Limits.
ShowPAGC	3	4	Show power level for AGC mode.
ShowPMGC	4	4	Show power level for MGC mode.
ShowFREQ	5	6	Show frequency.
ShowSKEY	7	3	Show soft key.
ShowBurstPar	8	7	Show burst parameters.
ShowSweepPar	9	13	Show sweep parameters.
ShowSVER	13	8	Show controller Soft/Hard version.
ShowMEAS	14	10	Show measurements.
ShowSTA	15	5	Show status.
REJ	42	2	Unknown frame.

3.7.4 Frames

A. Frames from the host to the controller

A1. SetLIMITS – Set limits

HEAD	LEN	CTRL	DATA								CRC
0x96	10	2	FPLH	FPLL	RPLH	RPLL	nu	nu	NU	NU	xx

In response, the controller sends **ShowLIMITS** frame.

FPLH- HighByte,

FPLL- LowByte,

<FPLH, FPLL>=ForwardPowerLimit =two bytes set for ForwardPowerLimit. Scale is dW,

Example: ForwardPowerLimit=1=0.1W

RPLH- HighByte,

RPLL- LowByte,

<RPLH, RPLL>=ReversePowerLimit = two bytes set for ReversePowerLimit. Scale is dW,

Example: ReversePowerLimit=1=0.1W

nu – not used.

A2. SetPAGC – Set power level for AGC mode

HEAD	LEN	CTRL	DATA				CRC
0x96	4	3	AGCPoH		AGCPoL		xx

In response, the controller sends ShowPAGC frame.

AGCPoH - HighByte

AGCPoL - LowByte

<AGCPoH, AGCPoL> = AGCPowerLevel=two bytes set power level for AGC mode. Scale is dW,

Example AGCPowerLevel=1=0.1 W

A3. SetPMGC – Set power level for MGC mode

HEAD	LEN	CTRL	DATA				CRC
0x96	4	4	MGCPoH		MGCPoL		xx

In response, the controller sends **ShowPMGC** frame.

MGCPoH - HighByte

MGCPoL - LowByte

<MGCPoH, MGCPoL> = MGCPowerLevel=two bytes set power level for MGC mode. Scale is 0.1%,

Example MGCPowerLevel=1=0.1 %

A4. SetFREQ – Set internal source frequency

HEAD	LEN	CTRL	DATA				CRC
0x96	6	5	FreqH	FreqL	FreqHzH	FreqHzL	xx

In response controller sends ShowFREQ frame.

FreqH- HighByte,

FreqL- LowByte,

FreqHzH- HighByte,

FreqHzL- LowByte,

<FreqH, FreqL> = Freq. = two bytes Frequency setting , Scale is 1kHz, it means Freq=1=1 kHz

<FreqHzH, FreqHzL>=FreqHz= two bytes Frequency setting ,

Scale is 1Hz, it means FreqHz=1=1 Hz

Current Frequency setting is equal:

$$\text{Frequency} = \text{Freq} * 1000 + \text{FreqHz} \text{ [Hz]}.$$

A5. SetSKEY – Set softkey

HEAD	LEN	CTRL	DATA	CRC
0x96	3	7	Soft Key	xx

In response, the controller sends ShowSKEY frame.

Table 3.4 SoftKey bits

Soft Key		
BIT	Name	Description
7	SoftOn	=1 Host takes over the keyboard of controller. =0 Controller takes over the keyboard of controller. If you want to control the keyboard by the host and controller, you will send first command SetSKEY with SoftOn=1, then wait for response. Afterwards send SetSKEY with SoftOn=0.
6	Nu	Reserved
5	Nu	Reserved
4	Nu	Reserved
3	Key1	=1 Key1 is on, =0 Key1 is off.
2	Key0	=1 Key0 is on, =0 Key0 is off.
1	Key2	=1 Key2 is on, =0 Key2 is off.
0	Key3	=1 Key3 is on, =0 Key3 is off.

A6. SetBurstPar - Set burst mode parameters

HEAD	LEN	CTRL	DATA				CRC
0x96	7	8	SCode	BrepTL	BOnTH	BOnTL	xx

In response, the controller sends **ShowBurstPar** frame.

SCode = 0 Burst mode OFF request,
 = 1 Internal Burst mode ON request,
 = 2 Change burst parameters without changing burst on/off.
 = 3 Enable External Burst mode.

BRepTH - HighByte,

BRepTL - LowByte,

< BRepTH, BRepTH > = BRep Repetition period burst cycle. Scale is 1ms.
 BRep range=<1ms,50ms>.

BOnTH- HighByte,

BOnTL- LowByte,

< BOnTH ,BOnTH > = BOn Time of Power nn in burst cycle. Scale is 1us.
 BOn range=<1us,500us>

A7. SetSweepPar - Set sweep mode parameters

HEAD	LEN	CTRL	DATA					CRC	
0x96	13	9	SCode	SStr	SStp	SCyc	SStrHz	SStpHz	xx

In response, the controller sends **ShowSweepPar** frame.

SCode = 0 Sweep mode OFF request,
 = 1 Sweep mode ON request,
 = 2 Change sweep parameters without changing sweep mode on/off.

SStr= [Word=HighByte, LowByte] Start frequency in the Sweep mode. Scale is kHz,

SStp=[Word=HighByte, LowByte] Step frequency in the Sweep mode. Scale is kHz,

Scyc= [Word=HighByte, LowByte] Number of steps in full sweep cycle.

SStrHz=[Word=HighByte, LowByte] Two bytes SStr offset. Scale in Hz.
 SStrHz range=<0,999>Hz

SStpHz=[Word=HighByte, LowByte] Two bytes SStp offset. Scale in Hz.
 SStpHz range=<0,999>Hz

Current start frequency setting is equal:

$$\text{StartFrequency} = \text{SStr} * 1000 + \text{SStrHz} \text{ [Hz]}$$

Current frequency step setting is equal:

$$\text{StepFrequency} = \text{SStp} * 1000 + \text{SStpHz} \text{ [Hz]}$$

A8. GetLimits – Get limits.

HEAD	LEN	CTRL	CRC
0x96	2	18	Xx

In response, the controller sends **ShowLIMITS** frame.

A9. GetPAGC – Get power level for AGC mode.

HEAD	LEN	CTRL	CRC
0x96	2	19	Xx

In response the controller sends **ShowPAGC** frame.

A10. GetPMGC – Get power level for MGC mode.

HEAD	LEN	CTRL	CRC
0x96	2	20	Xx

In response the controller sends **ShowPMGC** frame.

A11. GetFREQ – Get internal source frequency.

HEAD	LEN	CTRL	CRC
0x96	2	21	Xx

In response the controller sends **ShowFREQ** frame.

A12. GetSKEY – Get soft key

HEAD	LEN	CTRL	CRC
0x96	3	23	Xx

In response the controller sends **ShowSKEY** frame.

A13. GetBurstPar – Get Burst Parameters

HEAD	LEN	CTRL	CRC
0x96	2	24	Xx

In response the controller sends **ShowBurstPar** frame.

A14. GetSweepPar – Get Sweep Parameters.

HEAD	LEN	CTRL	CRC
0x96	2	25	Xx

In response the controller sends **ShowSweepPar** frame.

A15. GetSVER – Get controller software and hardware version

HEAD	LEN	CTRL	CRC
0x96	2	29	Xx

In response, the controller sends **ShowSVER** frame.

A16. GetMEAS – Get measurements

HEAD	LEN	CTRL	CRC
0x96	2	30	Xx

In response, the controller sends ShowMEAS frame

A17. GetSTA – Get status

HEAD	LEN	CTRL	CRC
0x96	2	31	Xx

In response, the controller sends ShowSTA frame.

B. Frames from the controller to host

B1. ShowLIMITS - Show limits

HEAD	LEN	CTRL	DATA								CRC
0x96	10	2	FPLH	FPLL	RPLH	RPLL	Nu	nu	nu	nu	xx

FPLH- HighByte,

FPLL- LowByte,

<FPLH, FPLL>=ForwardPowerLimit =two bytes set for ForwardPowerLimit. Scale is dW,
Example ForwardPowerLimit=1=0.1W

RPLH- HighByte,

RPLL- LowByte,

<RPLH, RPLL>=ReversePowerLimit = two bytes set for ReversePowerLimit. Scale is dW,
Example ReversePowerLimit=1=0.1W

nu – not used.

B2. ShowPAGC - Show power level for AGC mode.

HEAD	LEN	CTRL	DATA		CRC
0x96	4	3	AGCPoH	AGCPoL	xx

AGCPoH - HighByte

AGCPoL - LowByte

<AGCPoH, AGCPoL> = AGCPowerLevel= two bytes set power level for AGC mode. Scale is dW,
Example AGCPowerLevel=1=0.1 W

B3. ShowPMGC - Show power level for MGC mode.

HEAD	LEN	CTRL	DATA		CRC
0x96	4	4	MGCPoH	MGCPoL	xx

MGCPoH - HighByte

MGCPoL - LowByte

<MGCPoH, MGCPoL> = MGCPowerLevel=two bytes set power level for MGC mode. Scale is 0.1%,
Which means MGCPowerLevel=1=0.1 %

B4. ShowFREQ - Show internal source frequency

HEAD	LEN	CTRL	DATA				CRC
0x96	6	5	FreqH	FreqL	FreqHzH	FreqHzL	xx

FreqH- HighByte,

FreqL- LowByte,

FreqHzH- HighByte,

FreqHzL- LowByte,

<FreqH, FreqL> = Freq = two bytes Frequency setting, Scale is 1kHz,
Which means Freq=1=1 kHz

<FreqHzH, FreqHzL> = FreqHz = two bytes Frequency setting, Scale is 1Hz,
Which means FreqHz=1=1 Hz

Current Frequency setting is equal:
Frequency=Freq*1000+FreqHz [Hz].

B5. ShowSKEY - Show softkey

HEAD	LEN	CTRL	DATA	CRC
0x96	3	7	Soft Key	xx

Table 3.4 SoftKey bits

Soft Key		
Bit	Name	Description
7	SoftOn	=1 Host takes over the keyboard of controller. =0 Controller takes over the keyboard of controller.
6	Nu	Reserved
5	Nu	Reserved
4	Nu	Reserved
3	Key1	=1 Key1 is on, =0 Key1 is off.
2	Key0	=1 Key0 is on, =0 Key0 is off.
1	Key2	=1 Key2 is on, =0 Key2 is off.
0	Key3	=1 Key3 is on, =0 Key3 is off.

B6. ShowBurstPar - Show burst mode parameters

HEAD	LEN	CTRL	DATA				CRC	
0x96	7	8	SCode	BRepTH	BrepTL	BOnTH	BOnTL	xx

SCode = 0 Burst mode is OFF,
 = 1 Internal Burst mode is ON,
 = 2 Change burst parameters without changing burst on/off.
 = 3 External Burst mode is enable.

BRepTH- HighByte,
 BRepTL- LowByte,
 < BRepTH ,BRepTH >= BRep Repetition period burst cycle. Scale is 1ms.
 BRep range=<1ms,50ms>.

BOnTH- HighByte,
 BOnTL- LowByte,
 < BOnTH ,BOnTH > = BOn Time of Power nn in burst cycle. Scale is 1us.
 BOn range=<1us, 500us>

B7. ShowSweepPar - Show sweep mode parameters

HEAD	LEN	CTRL	DATA						CRC
0x96	13	9	SCode	SStr	SStp	SCyc	SStrHz	SStpHz	xx

SCode = 0 Sweep mode OFF request,
 = 1 Sweep mode ON request,
 = 2 Change sweep parameters without changing sweep mode on/off.

SStr= [Word=HighByte, LowByte] Start frequency in the Sweep mode. Scale is kHz,
 SStp=[Word=HighByte, LowByte] Step frequency in the Sweep mode. Scale is kHz,
 Scyc= [Word=HighByte, LowByte] Number of steps in full sweep cycle.

SStrHz=[Word=HighByte, LowByte] Two bytes SStr offset. Scale in Hz.
 SStrHz range=<0,999>Hz

SStpHz=[Word=HighByte, LowByte] Two bytes SStp offset. Scale in Hz.
 SStpHz range=<0,999>Hz

Current start frequency setting is equal:
 StartFrequency=SStr*1000+SStrHz [Hz]
 Current frequency step setting is equal:
 StepFrequency=SStp*1000+SStpHz [Hz]

B8 ShowSVER - Show controller software and hardware version

HEAD	LEN	CTRL	DATA						CRC
0x96	8	13	SNH	SNL	SVerH	SVerL	DVerH	DVerL	xx

SNH- HighByte,
 SNL- LowByte,
 <SNH, SNL>= Serial Number two bytes information about Serial Number,

SVerH- HighByte
 SVerL- LowByte,
 <SVerH, SVerL>= Software Version two bytes information about Software Version,

DVerH- HighByte,
 DVerL- LowByte,
 <DVerH, DVerL>= Device Version two bytes information about Device Version,

B9. ShowMEAS - Show measurements

HEAD	LEN	CTRL	DATA								CRC
0x96	8	13	FPH	FPL	RPH	RPL	nu	nu	TPH	TPL	xx

FPH- HighByte,

FPL- LowByte,

<FPH, FPL>= Forward Power

current measured ForwardPower. Scale is dW,
it means ForwardPower=1=0.1 W

RPH- HighByte,

RPL- LowByte,

<RPH, RPL>= ReversePower

current measured ReversePower. Scale is dW,
it means ForwardPower=1=0.1 W

TPH- HighByte,

TPL- LowByte,

<TPH, TPL>= ADCTemp

current measured Temperature.
Temperature= ADCTemp/26.4[°C]

nu – not used ,

B10. ShowSTA - Show current controller state

HEAD	LEN	CTRL	DATA			CRC
0x96	5	15	MainState	State	KeyState	xx

Bytes:

MainState	
Value	Description
0	Initialization.
1	Controller is in safe loop.
2	Controller is waiting for RFPowerOn Request in LocalMode
3	Controller is waiting for confirm of RFPowerOn in LocalMode
4	Controller is in main loop of the LocalMode
5	Controller is waiting for RFPowerOn Request in RemoteMode
6	Controller is waiting for confirm of RFPowerOn in RemoteMode
7	Controller is in main loop of the RemoteMode

State		
Bit	Name	Description
7	FstRemote	=1 Controller works in RemoteMode, =0 Controller works in LocalMode.
6	FStExtBurst	=1 External Burst Mode is working =0 External Burst Mode is not working.
5	FStRfError	=1 RfError detected, =0 RfError not detected.
4	FStSafetyLP	=1 error of the safety loop detected, =0 error of the safety loop not detected.
3	Nu	Reserved
2	FStExceedRP	=1 limit of the ReversePower detected, =0 limit of the ReversePower not detected.
1	FStExceedFP	=1 limit of the ForwardPower detected, =0 limit of the ForwardPower not detected.
0	FStExceedTmp	=1 temperature error detected =0 temperature error not detected.

KeyState		
Bit	Name	Description
7	SoftOn	=1 Host takes over the keyboard of controller, =0 Controller takes over the keyboard of controller.
6	Nu	Reserved
5	Nu	Reserved
4	Nu	Reserved
3	Key1	=1 Key1 is on, =0 Key1 is off.
2	Key0	=1 Key0 is on, =0 Key0 is off.
1	Key2	=1 Key2 is on, =0 Key2 is off.
0	Key3	=1 Key3 is on, =0 Key3 is off.

B11. REJ – rejected frame – incorrect command

HEAD	LEN	CTRL	CRC
0x96	2	42	Xx

3.8 Examples

3.8.1 CRC Calculation

Function in C language:

```
        BYTE CalcCRC(BYTE dat, BYTE crc)
{ int i;
  for(i=0;i<8;i++)
    { if((crc ^ dat) & 0x01)
      { crc=crc ^ 0x18;
        crc=crc >> 1;
        crc=crc | 0x80;
      }
      else
      { crc=crc >> 1;
        crc=crc & 0x7f;
      }
      dat=dat >> 1;
    }
  return(crc);
}
```

In Transmitted Frame, first set variable crc=0, then call CalcCRC for fields HEAD.LEN, CTRL and DATA, and write variable crc in field CRC.

Received frame is correct if calculated crc from fields HEAD, LEN, CTRL, DATA is equal CRC field from received frame.

3.8.2 Initialization

Exemplary transactions in the initialization stage.

HOST

CONTROLLER

GetLIMITS

ShowLIMITS

GetPAGC

ShowPAGC

.

.

.

GetSweepPar

ShowSweepPar

3.8.3 Measure

Exemplary transactions for continuous measure

HOST

CONTROLLER

GetMEAS

ShowMEAS

GetMEAS

ShowMEAS

GetMEAS

ShowMEAS

5.3. Setting

Exemplary transactions for setting PowerLevel for AGC mode.

HOST

CONTROLLER

SetPAGC

ShowPAGC

Appendix

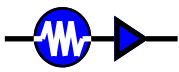

AG 1024 Specifications

Class Of Operation

Class "B"

Frequency Of Operation

20 kHz to 3 MHz

RF Power Output

50 Ohm load:

Up to 2000W for 20 kHz to 1 MHz

Up to 1000W for 1 MHz to 2 MHz

Up to 400 W for 2 MHz to 3 MHz

Pulse and low duty cycle!

Any load:

Up to 1800W , continues operation.

Gain

63 dB @ 2000W / 0.5 MHz

±1.5 dB 20 kHz to 1 MHz

RF Input Drive for AGC

Recommended -5 dBm to 0 dBm for ±0.5 dB gain flatness

Input Drive Source

Signal or function generator, analog computer input capable of up to 1 Vp-p @ 50 Ohm

Input range: -30 to 0 dBm typical, +5 dBm maximum

Internal RF Source

DDS oscillator: 20 kHz to 3 MHz, 1 kHz resolution

Input and Output Impedance

50 Ohm

2:1 max INPUT VSWR

3:1 max OUTPUT VSWR

Output VSWR Protection

400 W max reflected power limit for Load Impedance > 50 Ohm. Current level protection for Load Impedance < 50 Ohm.

Harmonic Level @ 1750W

Better than - 13 dBc for 3-d harmonic, any other better than -20 dBc

T&C Power Conversion, Inc.

110 Halstead Street, Suite 7

Rochester, NY 14610, USA

Tel: 585-482-5551

Fax: 585-482-8487

<http://www.TCPowerconversion.com>

Spurious Output

- 26 dBm equivalent noise level generated by internal circuits

RF Output Settings & Control

- Front Panel EDITOR and function switches for manual control,
- RS232 port for GUI or other computer communication. Rear Panel.

- SubD 25 Analog and Digital I/O .
Port power scale 1V=250W. Rear Panel

BURST operation

Pulse range: 1 to 500 usec

Period: 1 to 50 milliseconds

User settings via GUI and RS232

BURST - external

DC to > 200 kHz. User defined

BURST scheme via SubD-25.

See analog port description for more details.

SWEEP operation

0.02 to 3MHz. Min time 10 ms, max 10s. Settings and activation from GUI only.

Output Blanking

For pulsed applications, T&C amplifiers and generators offer blanking of the output signal for minimum noise RF spectrum

RF Connectors

BNC Female: RF In

N Female: RF Out

AC Power Connection

See manual for details

AC Input Ratings

2/N/PE ~ 200-240 V, 35 A, 50-60 Hz

2/N/PE ~ 200 V, 42 A, 50-60 Hz

2/N/PE ~ 346-415 V, 16 A, 50-60 Hz

Cooling

Forced air, temperature controlled, heatsink temperature monitored via RS232 GUI interface.

Acoustic level:

45dBa @ Max Fan Speed @ temp.

Case

Designed to meet EMI and RFI shielding requirements steel chassis (frame), black conductive finish. Cover, Front and Back Panels AL with yellow conductive finish. Exterior: Front & Back Panel: T&C off-white. Cover: T&C black.

Dimensions

533 mm x 520 mm x 470 mm

(21"x 20.5" x 18.5")

Weight: 71.4 kg, 157.5 lbs.

Mounting

Stand alone unit.

Environmental conditions

Temp.: 10° to 40° C ambient

Humidity: 80%

Equipment intended for ISM applications in laboratory and light industrial environment.

AG 1024 Performance Chart

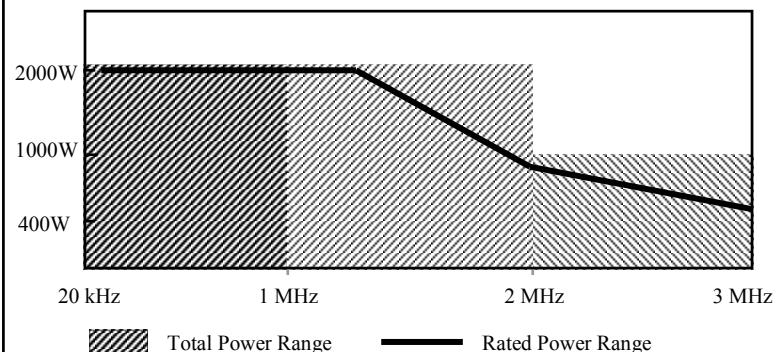

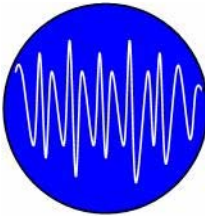

T&C Power Conversion, Inc.

110 Halstead Street
Rochester, New York 14610 USA
e-mail: sales@TCPowerConversion.com

Phone: 1 585 482 5551
Fax: 1 585 482 8487

EC Declaration of Conformity
according to 98/37/EC
according to EC EMC Directive 89/336/EEC
And according to EC Low Voltage Directive 73/23/EEC

We, *T&C Power Conversion, Inc.*

of *110 Halstead Street, # 7*
Rochester, NY 14610, USA

herewith declare, that the following product complies with the appropriate basic safety and health requirements of the EC Directive based on its design and type, as brought into circulation by us. In case of alteration of the product, not agreed upon by us, this declaration will lose its validity.

Product Description: Amplifier Generator

Model Number: AG 1024

Applicable EC Directive(s): 73/23/EEC - The Low Voltage Directive
and its amending directives

89/336/EEC - The Electromagnetic Compatibility Directive
and its amending directives

Applicable Harmonized Standards: EN 61010-1:2001 (2nd Edition)
EN 61326-1: 1997 + A1:1998 +A2:2001 +A3:2003

Authorized Signature: *Tomasz Mokrzan* **Date:** 12/04/06

Name: Tomasz Mokrzan

Title of Signatory: General Manager

CE 06