

**T&C**  
Power Conversion

**T&C POWER CONVERSION**

---

# Model AG 0313

---

## 13.56 MHz, 300 W RF POWER SOURCE



# OPERATION MANUAL

110 Halstead Street  
Rochester, New York 14610  
USA  
Tel: 585.482.5551  
Fax: 585.482.8487  
[www.tcpowerconversion.com](http://www.tcpowerconversion.com)  
[sales@tcpowerconversion.com](mailto:sales@tcpowerconversion.com)

- THIS PAGE INTENTIONALLY LEFT BLANK -

# AG 0313

---

## 13.56 MHz, 300 W RF POWER SOURCE



**HIGH RF VOLTAGES MAY BE PRESENT AT THE OUTPUT OF THIS UNIT.** All operating personnel should use extreme caution in handling these voltages and be thoroughly familiar with this manual.



**DO NOT USE ANY CFC (CHLOROFLUOROCARBON) SOLVENT IN THE MAINTENANCE OF THIS PRODUCT.** The no-clean flux used in manufacturing this product may leave a small inert residue, which will not affect the performance of the product. The use of CFC's for cleaning or maintenance may result in partial liquefaction of the no-clean flux residue, which will damage the unit and void the warranty.

This product is manufactured at T&C Power Conversion's Rochester, NY plant, following ISO 9001 Quality System principals.



**Applicable EC Directives:** EC Low Voltage Directive 73/23/EEC  
EC Electromagnetic Compatibility 89/336/EEC

**Applicable Harmonized Standards:**

EN 61010-1:2001 (2nd Edition), UL 61010-1  
EN 61326-1:1997 + A1:1998 + A2:2001 + A3:2003

### **NOTICE:**

The material contained in this manual is subject to change without notice. No part of this manual may be reproduced or utilised in any form or by any means, electronic or mechanical, including photocopying or electronic transmission or other means of reproduction or distribution without prior written consent of T&C POWER CONVERSION, INC.

The drawings, specifications and other technical information contained in this manual are the property of T&C POWER CONVERSION, INC. and shall not be copied, reproduced or used in any way, in whole or in part, as basis of manufacture or sale of similar items without the prior written consent of T&C POWER CONVERSION, INC.

© 2008 T&C POWER CONVERSION, INC.

- THIS PAGE INTENTIONALLY LEFT BLANK -

---

## WARRANTY

---

T&C POWER CONVERSION, INC. warrants to original Purchaser/User for a period of 12 months from the date of delivery each instrument to be free from defects in materials and workmanship.

For a period of 12 months T&C will, at its opinion, adjust, repair, or replace defective parts without charge to the original purchaser, so that the instrument performs according to its specifications.

When warranty service is required, the instrument must be returned, transportation prepaid, to the factory.

If, in our opinion, the instrument has been damaged by accident, unreasonable use– inconsistent with user’s manual, improper site preparation or maintenance, or abnormal condition of operation – repairs will be billed at the standard rate to Purchaser. In these cases, an estimate will be submitted to User before the work is started.

---

## SERVICE AND TECHNICAL ASSISTANCE

---

For service or repair, contact T&C directly or a local representative with the following information:

- Model and serial number.
- Purchase order number.
- Detailed description of malfunction.

For technical assistance for your particular application contact the factory. The following information will help us provide you with prompt and efficient service:

- All information displayed on the LCD.
- Detailed description (e.g. physical damage and/or performance anomalies, quantitative and/or qualitative deviation from specification), including miscellaneous symptoms, dates and times.
- The environment and circumstances under which the issue developed.

Supporting test data and/or records that are available.

---

## Sales & Service Locations

---

Look for our currently updated Sales and Service Representatives around the world on our website:

[www.tpowerconversion.com/about/representatives.html](http://www.tpowerconversion.com/about/representatives.html)

- THIS PAGE INTENTIONALLY LEFT BLANK -

# PRODUCT MANUAL REVISION CONTROL FORM

Document Title: AG 0313 Operating Manual Revision History Control Page

Document Number: 9081 0041

Document Status: Open

## Revision History

ECO	Rev	Description	Effective Date
	C	Format update (MS Publisher)	8/20/04
	D	Format update to meet EN61010-1 requirements	01/14/05
	E	New package and new PA, controllers.	04/07/2008

	Name / Title	Signature	Date
<b>Written By</b>	Charles W. Beer Jr./Mfg Technician	<i>Charles W. Beer Jr</i>	Apr.15, 2008
<b>Approved By</b>	Tomasz J. Mokrzan/general manager	<i>Tomasz J. Mokrzan</i>	Apr.17, 2008

- THIS PAGE INTENTIONALLY LEFT BLANK -

---

# TABLE OF CONTENTS

---

<b>Warranty</b>	5
<b>Service and Technical Assistance</b>	5
<b>Product Manual Revision Control Form</b>	7
<b>Introduction</b>	11
<b>Chapter 1: Safety</b>	13
1.1 Labels	13
1.1.1 Important Operating or Maintenance Cautions	13
1.1.2 Electric Shock Warnings	13
1.1.3 Caution Warning	13
1.1.4 AC INPUT and Chassis Terminal	14
1.1.5 External RF IN	14
1.1.6 RF OUT	14
1.1.7 Miscellaneous Symbols	14
1.1.8 Service	15
1.1.9 Name Plate	16
<b>Chapter 2: System Installation</b>	17
2.1 Initial Installation	17
2.1.1 Mechanical Inspection	17
2.1.2 Claim for Damage	17
2.1.3 Packaging for Reshipment	17
2.2 Installation Requirements	18
2.3 Cooling and Ventilation	18
2.4 Power Line Voltage	18
2.5. System Interconnection	19
2.6 Initial Turn-On Procedure	19

<b>Chapter 3: Operation</b>	<b><u>Page</u></b>
3.1 Introduction	20
3.2 GUI Operation	21
3.3 Rear Panel Control Interface	22
25-Analog Remote Interface Schematic Diagram	23
Analog Communication Port DB-25 Connection	24
3.4 Front Panel Controls and Display	25
Menu Structure	27
<b>Appendix:</b>	28
AG 0313 Specifications	29
<b>Technical Diagrams</b>	
Functional Block Diagram	30
Mounting and Outline Drawing	31

---

# INTRODUCTION

---

The T&C Power Conversion, Inc. Model AG 0313 13.56 MHz RF Power Source is a totally solid state, air cooled RF power source expressly designed for use in general ultrasonic and gas plasma applications. The RF Power Source utilizes conservatively rated solid state components and automatic power control circuitry to ensure reliable and continuous performance. Completely self-contained, the AG 0313 provides all of the control and monitoring functions needed in a state-of-the-art power generator, which will provide up to 300 W of continuous output into a 50 Ohm load.

The AG 0313 measures forward power, load power, reflected power, and the operating temperature of its power amplifier module. Should any of these parameters exceed a preset limit, the power control circuit will immediately limit the generator's RF power output so that the components always remain within safe operating limits.

The AG 0313 is equipped with a rear panel control interface. The standard T&C Power Conversion, Inc. Analog Interface (see pages 22-24) allows control and monitoring of the generator through the use of Analog voltage control signals. The Analog Interface provides full control of the generator and allows for automated operation through the use of a computer at this port. Digital Communication (D-Com) Interface is used to control the unit or just to monitor the parameters.

The AG 0313 can accommodate a wide range of AC line voltages automatically. The unit also has an EMI filtered AC power entry to eliminate conducted line leakage.

Only minimum maintenance is required to guarantee successful operation and endurance of your AG 0313 RF Power Source. The unit's completely solid state design substantially reduces DC voltages which eliminates the hazards associated with servicing high-voltage vacuum tube equipment.

The AG 0313 is classified as ISM (Industrial/Scientific/Medical) type of an equipment.

This manual is divided into three chapters and an appendix. Please refer to the following descriptions to help you locate the information you need.

<b>Chapter</b>	
<b>1</b>	Deals with precautionary details. Please read this if you are unfamiliar with the AG 0313 or T&C Power Conversion's warranty procedures
<b>2</b>	Explains how to install and power up the system for the first time
<b>3</b>	Describes the operating details of the AG 0313
<b>Appendix</b>	Technical Specifications

## 1.1 Labels

Labels are provided to alert operating and service personnel to conditions that may cause personal injury or damage to the equipment from misuse or abuse. Please read the labels and understand their meaning.

### 1.1.1 Important Operating or Maintenance Caution



Definition: Attention, consult accompanying document

The exclamation point within a triangle alerts the user, operator, or service personnel to the presence of important operating and/or maintenance instructions in the User's Manual.



### 1.1.2 Shock Hazard Warning

Definition: Caution, risk of electric shock

The lightning bolt within a triangle alerts the user, operator, or service personnel to the presence of unprotected voltage points within the enclosure of sufficient magnitude to cause dangerous electrical shock.

Only authorised service personnel with the schematic diagram and knowledge of the voltages within the equipment shall remove covers or panels bearing this symbol.

### 1.1.3 CAUTION WARNING

**Do not operate this RF Power Supply with the cover removed.** Lethal voltages are present beneath the cover. The cover protects against **Electrical shock** due to AC line voltage, high RF potential in the hundreds of Volts at the output transformer, coupler and output connections. Also the DC supplies produce high voltages in the conversion process and are capable of producing more than 25 Amps of current at nominal output voltage. The cover is an integral part of the air ducting system that keeps components cool. Without the cover in place, insufficient air flows between and around the two DC power supplies causing overheating of the internal components.

Always connect the load to the RF output connector before connecting the RF input to the amplifier. This will ensure that high voltage at the center pin of the output N connector will not be exposed. Take care not to interchange the input and output cables.

## Chassis Terminal

Be sure the chassis is grounded to a reliable earth ground using the grounding stud provided on the rear panel. In addition, be sure the grounding wire remains connected securely between the cover of the chassis and the base of the chassis.

### 1.1.4 AC INPUT – Alternating current input

Definition: AC Input ratings for operation

100-120 V ac, 50-60 Hz, 7.0 A

200-240 V ac, 50-60 Hz, 3.5 A

**Chassis Terminal** — For connection of AG 0113 to a proper safety ground

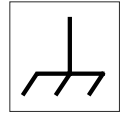

### 1.1.5 External RF IN

Definition: RF Input

The External RF IN symbol identifies the signal input port for the user, operator, or service personnel.

### 1.1.6 RF OUT

Definition: RF Output

The RF OUT symbol identifies the signal output port for the user, operator, or service personnel.

### 1.1.7 Miscellaneous Symbols

AC Power Rocker Switch



AC Power Off Symbol

Figure 3

Definition: Off (power: disconnection from the AC mains)

The Off symbol on the AC Power Switch identifies the functional configuration of the rocker switch for the user, operator, or service personnel.



AC Power On Symbol

Figure 4

Definition: On (power: connection to the AC mains)

The On symbol, next to the AC Power Switch identifies the functional configuration of the rocker switch for the user, operator or service personnel.

## 1.1.8 Service

T&C POWER CONVERSION, INC. is responsible for safety and performance of the equipment only if:



- Assembly operations, extensions, readjustments, modifications, or repairs are carried out by authorised personnel.



- The electrical installation is made in accordance with User's Manual and the room in which the equipment is installed complies with the environmental requirements.
- The equipment is used strictly in accordance with the instructions in this manual or associated test documents.

## 1.1.9 Name plate

The AG 0313 can be identified by a name plate on its rear side panel that contains the following information.

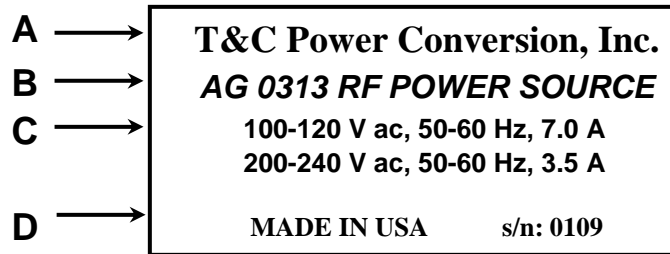

Figure 5      Name plate

### A. MANUFACTURER

T&C POWER CONVERSION, INC  
110 Halstead Street, Suite #7,  
Rochester, NY 14610  
USA

### B. MODEL NUMBER / TYPE OF EQUIPMENT

The assembly number which uniquely identifies product configuration is entered on this line. This line holds the description of what the equipment is intended to be used for.

### C. PRODUCT RATINGS

This line contains the product's rated voltages and currents.

### D. COUNTRY OF ORIGIN & SERIAL NUMBER

This line contains the country of origin as well as a number which is sequentially assigned as the product is manufactured.

# System Installation

---



**Note: Chapter 2 is for “Authorized Personnel” only, qualified in electrical installation**

## 2.1 Initial Installation

### 2.1.1 Mechanical Inspection

If damage to the shipping carton is evident, request the carrier’s agent be present when the unit is unpacked. Check for equipment damage and inspect the cabinet and panels for dents and scratches.

### 2.1.2 Claim for Damage

Please notify T&C Power Conversion, Inc. directly or your authorized T&C representative if the product is mechanically damaged or fails to meet specifications upon receipt. Retain the shipping carton and packing material for the carrier’s inspection as well as for subsequent use to return the unit should this become necessary.

### 2.1.3 Packaging for Reshipment

Whenever possible, the original shipping carton and packing material should be used for reshipment. If the original packing material is not available, wrap the instrument in heavy paper or plastic. Use a strong shipping container. If a cardboard carton is used, it should be at least 200 lbs. test material.

Use shock-absorbing material around all sides of the instrument to provide a firm cushion and to prevent movement inside the container wall on each side. Protect the front panel by means of cardboard spacers inserted between the front panel and the shipping carton. Make sure that the instrument cannot move in the container during shipping. Seal the carton with a good grade of shipping tape and mark the container:

**FRAGILE DELICATE INSTRUMENTS**

## 2.2 Installation Requirements

The AG 0313 is designed for bench or system operation. To guarantee the best performance, make sure there is adequate clearance for the entrance of cooling air to the front of the unit as well as for the exhaust out the back of the unit (6" or ~150 mm.min).

The AG 0313 is set for operation with a single phase, 50—60 Hz AC Line of 100-120 or 200 - 240 V. The power supply switches automatically to the line voltage applied to the unit. Unit does not require any special internal adjustments if operated within the specified voltage range.

### **Please check the following items before applying AC power to the AG 0313:**

- *Check Unit for any physical damage that could affect safety.*
- *Ensure the AC power cord is an IEC type with a 13 Amp or greater rating with a proper safety ground connection.*
- *The unit should be connected to an AC outlet that is easily accessible.*
- *Ensure the AC power cord is plugged into a properly grounded outlet..*
- *Connect AG 0313 chassis to a proper safety ground. (Use Grounding Stud on rear panel) A green insulated 14-gauge wire or heavier less than 50 feet in length is recommended.*

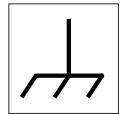

## 2.3 Cooling and Ventilation

The AG 0313 is protected against damage caused by lack of air flow. If inadequate air flow causes the temperature to rise over the OVERHEAT threshold, the RF Power Source senses an OVERHEAT fault, and RF power is automatically shut off. RF power will be restored automatically after the temperature falls below threshold.

For proper ventilation, adequate clearance of at least 6 inches (≈150 mm) should be provided for the cool air intake on the front panel of the amplifier/generator. The ports located on the rear panel of the unit, should have at least 6 inches (≈150 mm) of clearance and also be free from obstruction. To reduce potential overheating, do not allow exhausted warm air from the back to recirculate to the front of the unit.

**Maximum Ambient Temperature: 40°C**

## 2.4 Power Line Voltage

The AG 0313 is designed for operation from a single-phase, 3-wire electrical network with the following parameters:

100-120 V ac, 50-60 Hz  
or  
200-240 V ac, 50-60 Hz

## 2.5 System Interconnection

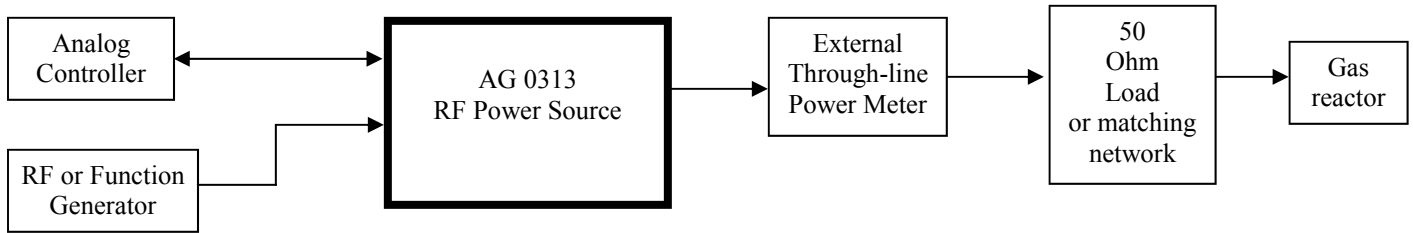

(For operation information refer to Chapter 3)

## 2.6 Initial Turn-On Procedure

The following procedure outlines a simple test to check for proper operation of the AG 0313 13.56 MHz RF Power Source. It is assumed that the RF Power Source is already connected to an appropriate AC power line, and a suitable 50 Ohm dummy load or matching network (as indicated in the diagram above).

Verify the AC Safety Interlock is Enabled (Pin 10 and 23 electrically shorted together, see page 26)

Turn ON the main AC switch on the front panel.

1. The screen should flash the name of the manufacturer, firmware version before displaying the power parameters.
2. Verify that the status LEDs are as shown below. Each button below the display contains two functions (except Source button— see Front Panel operation paragraph). Active function is indicated by a lit LED.



3. Run the test. Activate the RF Output  $\odot$ ON function and increase the RP (Requested Power) to 100W using Editor knob. The F (Forward Power) reading should be (300+/-1)W. The L (Load Power) reading should be (300+/-1)W and the R (Reverse Power) should be 0W. Next increase the RP to 320W. The FP reading should now read approximately 315W and note the status of FWR LIMIT LED: it should be on.
4. Set the RP back to 0W. With the RF Output  $\odot$ ON function still activated, press the Mode LED switch for the MGC function. Increase RP to 300W. Forward Power and Load Power readings should be around 300W.
5. Decrease RP to zero and switch back to AGC mode. Disconnect RF output, and increase the RP to 75W. Forward Power and Reverse Power readings should equal 70W. Note the status of the REV LIMIT LED: it should be on. When reducing below 70W, the REV LIMIT LED will be off.
6. Reduce RP to zero, and reconnect load.
7. This concludes the test. The unit is operating properly and ready for use.

### 3.1 Introduction

---

The AG 0313 is a bench top or rack mount RF Power Supply with practical features. On the left end of the front panel is the **AC line** power ON / OFF switch. This switch activates heavy-duty double pole relay that connects and disconnects the hot and neutral power line connections. The amplifier is shipped from the factory internally wired for 100 - 120 V ac or 200 - 240 V ac. with PFC. The power supply switches automatically to the line voltage applied to the unit.

The green indicator LED AC ON shows that AC power is connected to the unit, the power switch is on and the DC power is available to the controllers. The user must make sure that connecting cables to the RF output are also the 50-Ohm type, to keep the output power from being reflected back to the amplifier due to cable impedance mismatch.

A wide area of ventilating slots serve as the air intake for ventilating the generator. Operation of the generator necessitates removal of the heat generated by the amplifying devices. **The air intake must be kept clear of obstructions,** as should the fan outflow at the rear of the unit. Allow a minimum of 6" clearance around all sides of the chassis. The fan's speed is proportional to the temperature rise of the internal heat sink. There is also a high temperature cut out switch that shuts down the amplifier if the heatsink gets too hot. This could happen; for example, if the intake airflow is obstructed or the ambient air temperature is too great.

There are three ways to control the unit:

- a) using Graphic User Interface (GUI) (need computer with installed program T&C GUI, supplied with the unit);
- b) using the Analog Port;
- c) using the Front Panel's buttons and Editor knob.

Priorities of controls:

- 1) GUI when control mode switch in the software position
- 2) Analog Port when signal Generator Enable/Disable (pin8) is TTL Hi.
- 3) Front Panel

The front panel is master when:

- 1) In GUI control mode switch is in the analog port position or GUI is not running and
- 2) Analog Port when signal Generator Enable/Disable (pin8) is TTL Lo.

For all other combinations, the front panel works as slave and reflects the readings of the control device.

## 3.2 GUI Operation:

Use GUI Application User Manual (supplied with the unit) for installing the program and controlling the unit using a computer.

**Note:** The following functions on the Analog port remain active: pin 14—Blanking; pins 10 & 23—Interlock.

**Digital Communication Port (D-COM):** The digital communication port allows software control of the power supply from a PC compatible computer. The supplied *RF Power Source Graphical User Interface* software (T&C GUI) provides complete control and monitoring of all RF Power Source settings and functions.

This digital communication port has connections for RS 232, RS 485 as well as USB. These are in addition to the standard Analog Port. Refer to the *RF Power Source Graphical User Interface* software users guide for complete installation and operating details.

If you would like to control the RF Power Supply with your own custom software, refer to the *Communication Protocol for C10 Controller* document for detailed communication information.

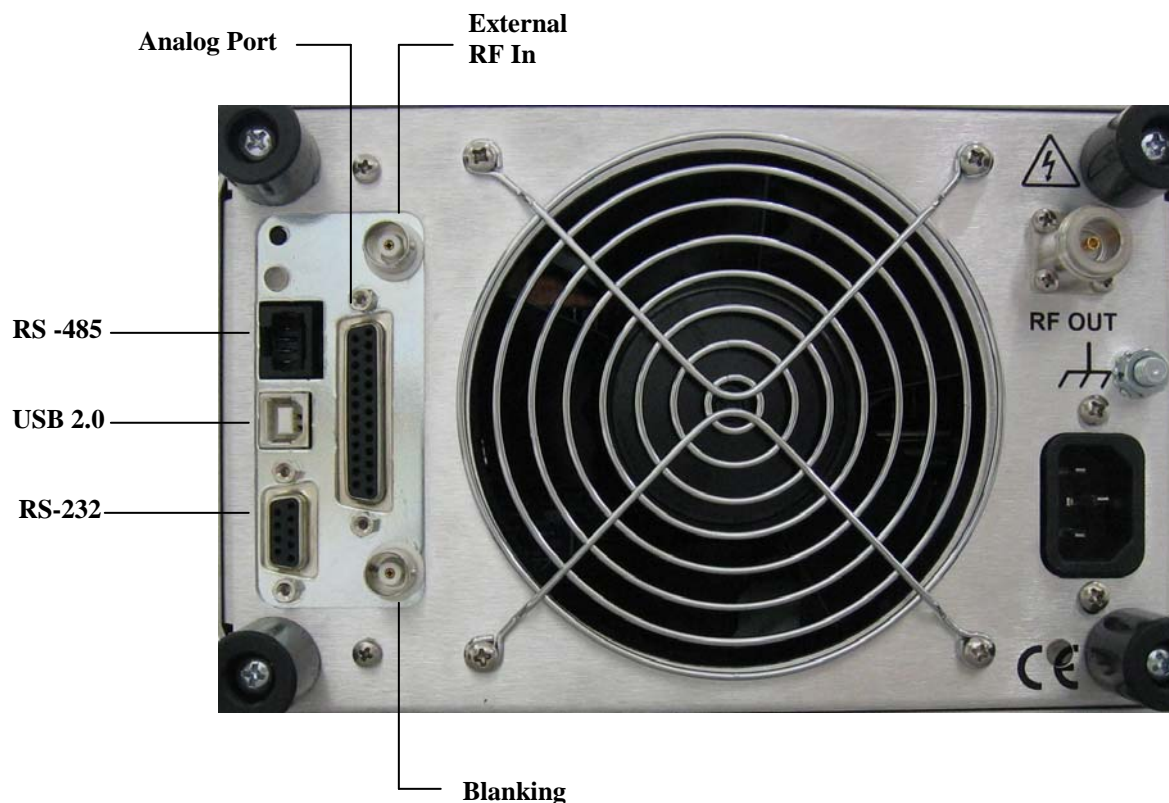

## 3.3 Rear Panel Control Interface:

**Description:** These additional features are provided by use of the Remote Control:

- *Power level adjustment and control.*
- *Access to forward, load, and reverse power level information.*
- *Status flags indicating power on, thermal limit, reverse power limit.*

**Operation:** The user must make an electrical connection between pins 10 and 23 to enable the AC Safety Interlock. To enable operation (RF ON Switch), a control signal TTL Hi must be applied to pin 8 of the rear panel connection. To control the unit's RF power level, pin 5 must be provided with a DC voltage proportional to the RF power level desired. Refer to the table of panel connector pin descriptions on page 23 of this manual.

The rear panel connector's socket pins are numbered 1 to 13 reading from bottom to top across the top row. Returning to the bottom, the bottom row is 14 to 25.

**Blanking and Pulsing:** The connector also has a blanking input on Pin 14. TTL Hi level on Pin 14 in relation to Pin 18, 19, 21 (Analog Ground) will interrupt the RF Output. The normal open condition allows normal operation. Pulsing can be accomplished by maintaining a positive TTL level on Pin 14 and pulsing it to ground and back to positive. The RF Output will then pulse in relationship to that DC pulse. Please contact the factory for special applications and uses.

NOTE: Central pin of BNC connector for BLANKING on the rear panel has the same function as to the pin 14.

NOTE: Pin 14 must never go negative in relation to Pin 18, 19, 21.

**External Burst:** Applying TTL Hi to pin16 will enable the operation External Burst operation. With External Burst Mode active, a TTL signal with a specific pulse time and width, can be applied to pin 15 of the DB-25 connector. The amplitude of the RF signal is controlled by the voltage on pin5—RF Power Reference.

**Note:** Applying TTL Hi to pin16 also means that the unit operates in the MGC mode.

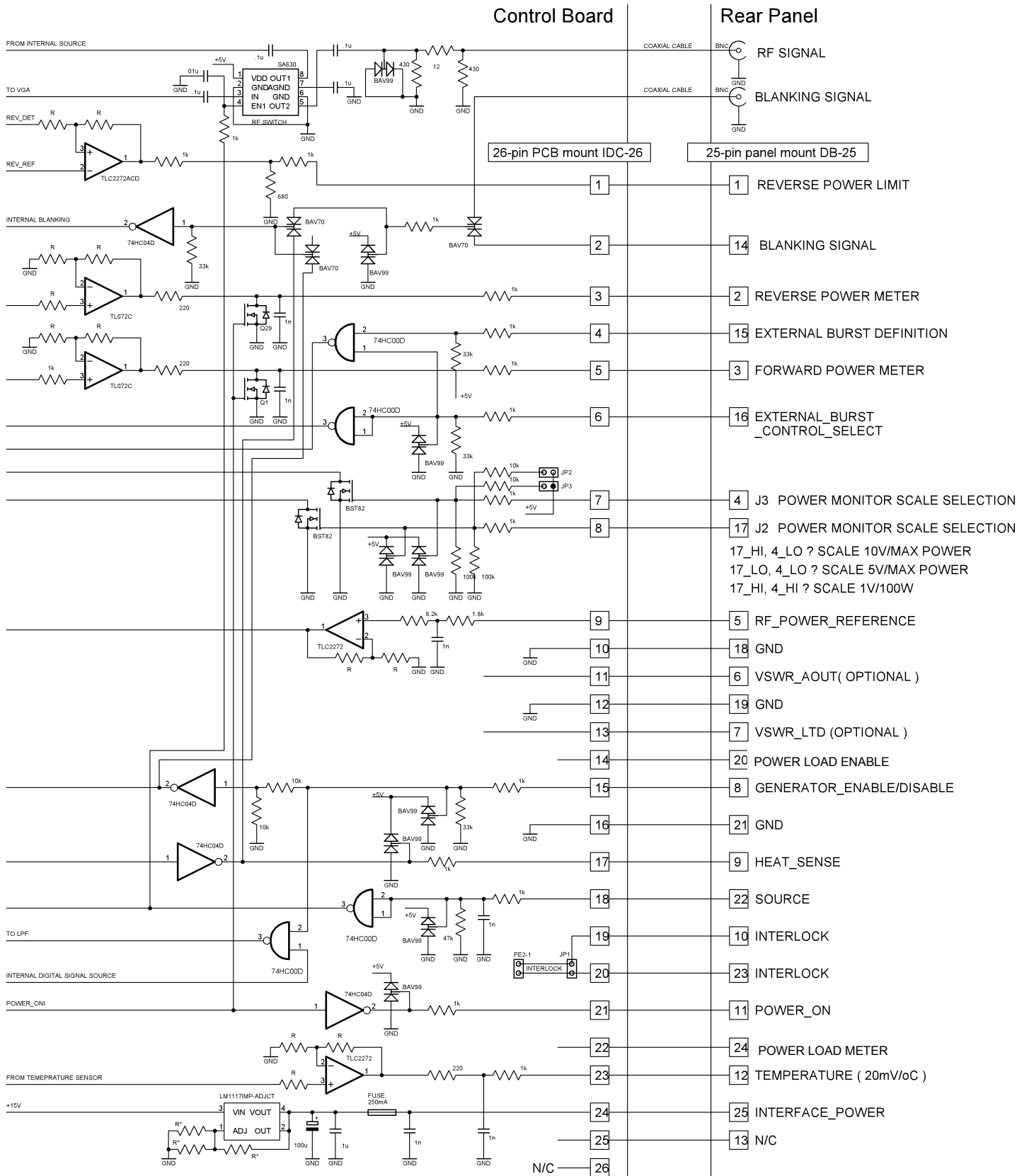

25 - pin Analog Remote Interface Schematic RF xx13

# Analog Communication Port DB-25 Connection:

Pin #	Name of Signal	Signal Description
1	REV LIMIT - This output indicates that output power level was automatically reduced under load mismatch conditions.	TTL Compatible; Hi = RF Out Limit, Lo = Normal operating condition at low VSWR. <b>Signal Direction: OUT</b>
2	REVERSE POWER	Refer to Power Monitor Scale Selection for scale settings. <b>Signal Direction: OUT</b> <b>NOTE:</b> contact factory for other settings.
3	FORWARD POWER	Refer to Power Monitor Scale Selection for scale settings. <b>Signal Direction: OUT</b> <b>NOTE:</b> contact factory for other settings.
4, 17	POWER MONITOR SCALE SELECTION	1 Vdc = 100W, Pin 4 = Hi, Pin 17=Hi, 10 Vdc = 300 W, Pin 4 =Lo, Pin 17=Hi, (default setting—Software Mode) 5 Vdc = 300 W, Pin 4=Lo, Pin 17=Lo, (default setting—Analog Port Mode) <b>Signal Direction: IN</b> <b>NOTE:</b> contact factory for other settings.
5	RF PWR REF	Linear voltage input, 5 Vdc = full power - (default scale). (Per selection on Pin 4 & 17, 10Vdc = full power or 1Vdc = 100W) <b>Signal Direction: IN</b> Part of AGC in default setting. Part of BURST if Pin 16 is HI. <b>NOTE:</b> contact factory for other settings.
8	GENERATOR ENABLE / DISABLE (RF ON/OFF)	TTL Compatible; Hi = RF OUTPUT ON, Lo = RF OUTPUT OFF, <b>Signal Direction: IN</b> <b>NOTE!</b> By default unit operates in AGC Mode.
9	HEAT SENSE - This output indicates that the unit has become too hot.	TTL Compatible; Hi = FAULT/Amp disable, Lo = amplifier enabled <b>Signal Direction: OUT</b>
10, 23	INTERLOCK	CONNECTED: RF power Supply enabled (ready for RF OUT) OPEN: Unit disabled (no RF OUT will generated) <b>Signal Direction: IN</b> <b>NOTE:</b> optional on special request. Default setting - disable by jumper on internal board, Enabled by removing jumper. Please contact factory for that option.
11	POWER ON: DC power applied to control circuit; indirect meaning AC is ON.	TTL Compatible; Hi = Power ON, Lo = Power OFF <b>Signal Direction: OUT</b>
12	TEMPERATURE MONITORING	20 mV/C <b>Signal Direction: OUT</b>
14	BLANKING SIGNAL	TTL Compatible Hi = interrupts RF at output connector, Lo = uninterrupted operation. <b>Signal Direction: IN</b>
15	EXTERNAL BURST - Defines Pulse Time and Width input.	TTL compatible input: Hi - BURST RF OUTPUT Lo - BURST RF OFF <b>Signal Direction: IN</b>
16	EXTERNAL BURST CONTROL SELECT	TTL compatible input: Hi - RF EXTERNAL BURST READY Lo - NO SIGNAL OR BURST OFF <b>NOTE:</b> when selected Pin 5 - RF PWR REF switches from AGC mode to MGC and defines the amplitude of output BURST.
20	POWER LOAD MODE ENABLE	TTL compatible input: Hi - BURST RF OUTPUT Lo - BURST RF OFF <b>Signal Direction: IN</b> <b>NOTE:</b> optional on special request.
18, 19, 21	ANALOG GROUND (BLANKING AND BURST RETURN)	Return for pin 14, 15 and 16
22	SOURCE	TTL Compatible; Lo (or nothing connected) - internal signal source Hi - external signal source selected <b>Signal Direction: IN</b>
24	POWER LOAD METER	Refer to Power Monitor Scale Selection for scale settings. <b>Signal Direction: OUT</b> <b>NOTE:</b> optional on special request.
25	INTERFACE POWER	12 V DC (250 mA limited by electronic protection) Other levels of 5 and 10 V available! Please contact factory. <b>Signal Direction: OUT</b>

## 3.4 Front Panel Controls and Display:



The front panel is master when:

- 1) In GUI control mode switch is the analog port position or GUI is not running and
- 2) Analog Port when signal Generator Enable/Disable (pin8) is TTL Lo.

Besides over combinations the front panel works as slave: indicates the status of the unit and power levels set using GUI or Analog Port.

There are five status LEDs on the left from display:

**AC ON:** indicates that the unit is connected to AC line.

**FWR LIMIT:** indicates that the forward power approaches the limit set during the calibration.

**REV LIMIT:** indicates that the reflected power approaches the limit set during the calibration.

**OVERHEAT:** indicates that the internal temperature is in the zone of unsafe operation. The controlling circuit will reduce the RF output and requested RF power level will be restored when the internal temperature is safe. Possible reason of the overheating: no adequate clearance for the entrance of cooling air to the front of the unit as well as for the exhaust out of the unit.

**INTERLOCK:** indicates that AC power is not applies to the main power supply: pin 10 and pin 23 of the analog port are not connected.

There are four buttons beneath the display, with two LEDs each. An illuminated LED indicates the active function or mode. These are used in conjunction with the “**EDITOR**” knob and the display to provide manual control. Four buttons are labeled **RF Output**, **Mode**, **Edit Power**, and **Source**. We will discuss each button’s purpose and operation, from left to right. The buttons will retain their default settings: RF Output–Off, Mode – AGC, Edit Power – FWD, Source – INT.

**RF OUTPUT:** RF Output will default to off each time unit is turned on. RF Output Off LED will illuminate. The RF Output button must be pushed to illuminate RF Output LED and allow the unit to operate.

### **MODE:**

**AGC:** Automatic Gain Control. Power output controlled by EDITOR knob which is used to select the power by varying internal gain setting to accomplish desired constant output power.

**MGC:** Manual Gain Control. Power output controlled by the EDITOR knob and the scale is not linear. Read Forward Power level of the display for desired value when adjusting EDITOR knob.

**Note:** Unit must be in MGC mode for blanking or burst.

### **EDIT POWER:**

**FWD:** Set desired Forward Power when adjusting the EDITOR knob.

**LOAD:** Set desired Load Power when adjusting the EDITOR knob. Load power is the power which is delivered to the load and it equals to the difference between Forward Power and Reverse Power.

### **SOURCE:**

**INT:** Unit is set for operation from the internal oscillator. The frequency of operation is 13.56 MHz.

**EXT:** Unit is set for operation from external signal generator. Connect the signal generator to the External RF In connector. Use specifications to set the desired frequency of operation and the power level from the signal generator.

**ESC:** This button is also used in the front panel menu mode and serves as the ESC button.

### **EDITOR knob:**

It is used to select the desired power level the unit will deliver to the load. The knob has OK button, By depressing the knob quickly, it toggles the adjustment option from units to tens of Watts, or from tens to hundreds of Watts.

By pressing the OK button for three seconds the display will show the front panel menu.

Rotate knob in order to choose Burst settings or LCD display settings.

See page 25 for Front Panel Menu Structure.

# FRONT PANEL CONTROLLER FOR AG series

## MENU STRUCTURE

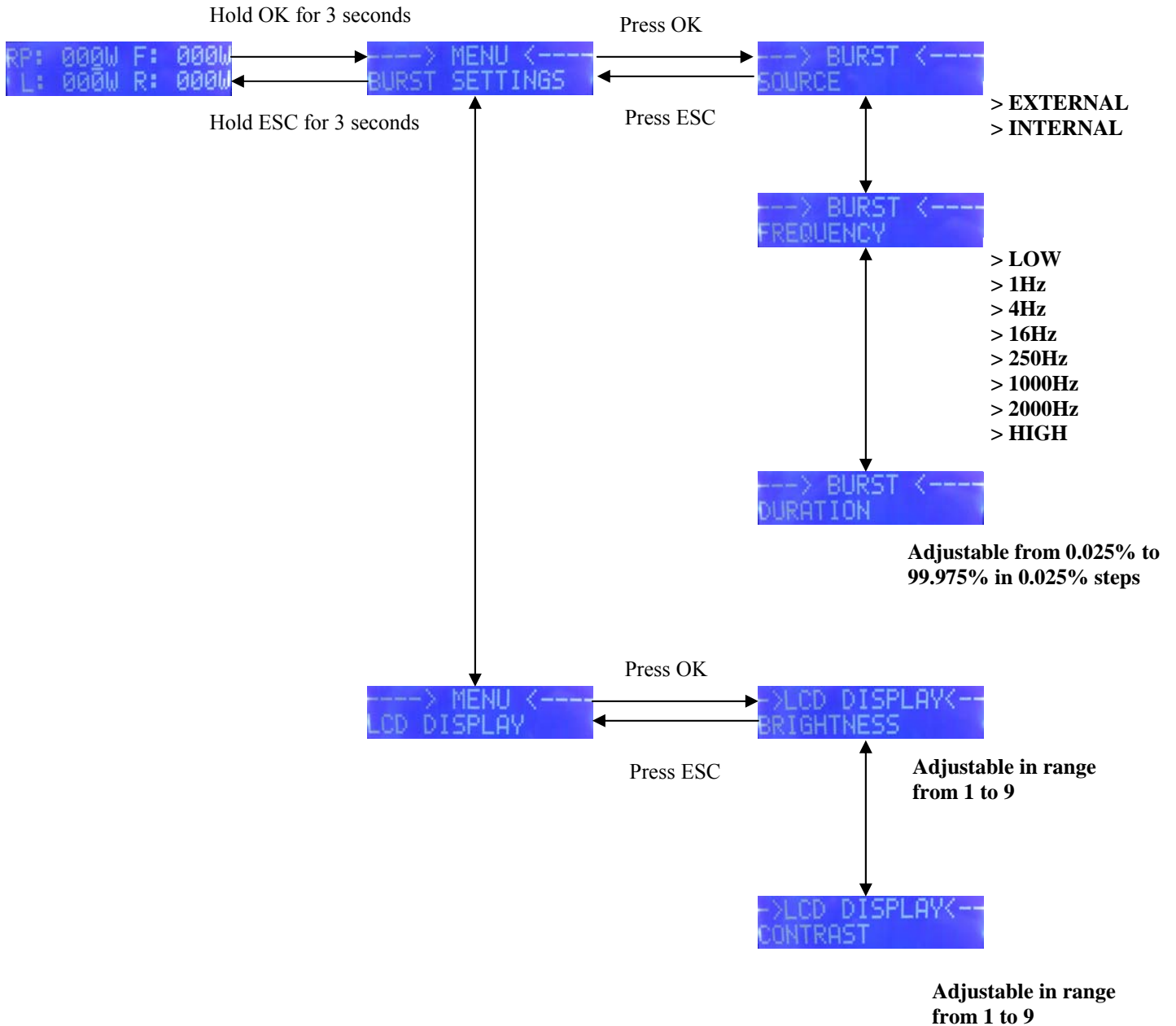

# Appendix

---

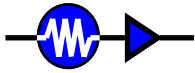

# AG 0313 Specifications



## Class Of Operation

Class C

## Frequency Of Operation

13.56 MHz

## Frequency Stability

0.005%

## RF Power Output

>300 Watts into 50 Ohm (FWD limit set for 315W)

**Operation as amplifier - optional.  
Contact T&C for further details.**

**Gain (as amplifier in BURST MGC Mode)** 54 dB @ 100W ±1 dB (0dBm IN Drive)

## RF Input Drive(as amplifier in BURST MGC)

Typical range -20 dBm to 0 dBm

## RF Input Drive for AGC

Recommended 0 dBm for the best operation

## Input Drive Source(amplifier)

Signal or function generator, analog input capable of up to 1 Vp-p @ 50 Ohm

## Internal RF Source

Crystal oscillator: 13.56 MHz,  
0.005% stability

## Input and Output Impedance

50 Ohm

**Input VSWR** 1.2:1 max

**Output VSWR** 3:1 max

## Output VSWR Protection

70 Watts max reflected power limit. Automatic, limits typically within 0.5 ms after reverse power reaches 70 Watts or power amplifier current preset limit.

## Harmonic Level @ 300W

Better than - 50 dBc for 2-nd harmonic, any other > -55 dBc

## Spurious Output

-55 dBm equivalent noise level at RF Out (generated by internal circuits )

## Mismatch Power Output

Forward power reference to rating:  
1.1:1 VSWR (50 Ω) up to 315W,  
315W FWD, 175W Load into 2:1,  
180W FWD, 115W Load into 3:1  
115W FWD, 43W Load into 9:1

## Dynamic Power Range

0 to 300W, settings within +/- 2W

## RF Output Settings & Control

- Front Panel EDITOR and function switches for manual control,
- RS232 port for GUI or other computer communication. Rear Panel.
- SubD 25 Analog and Digital I/O . Port power scale 1V=100W. Rear Panel

## Output Blanking/Pulsing

For pulsed applications, T&C amplifiers and generators offer blanking of the output signal for minimum noise RF spectrum. Less than 1µs Rise/Fall time

## Output Control Interfaces (Communications)

SubD 25 Analog and Digital I/O .  
D-COM "Digital Communication" Port: (Optional)  
RS-232  
RS-485  
USB

## Power Monitor Scale Selection

User selectable levels down to 1 watt (in three (3) Scales) within tenths of watt accuracy.

Available scales:  
1V=100W  
5V=full power  
10V=full power

## RF Power Meter accuracy

± 3% typical

## BURST - internal

User settings via GUI and RS232, 485 and USB or custom hardware port settings

## BURST - external

DC to > 200 kHz. User defined BURST scheme via SubD-25. See analog port description for more details.

## RF Power Margin

(Open Loop Max Power/Rated Power)-1)\*100  
50 %

## Rear Panel RF Connectors

INPUT BNC Female  
OUTPUT N Female

## AC Power Connection

IEC Standard Power Entry followed by RFI filter. Filter range 0.1 to 30 MHz min.

## AC Circuit Protection

Internally fused on the main DC Power Supply, 15A.

## AC Input Current (RMS)

### RF Out 300W:

100 to 120 V ac, 50-60Hz, 7.0 A  
200 to 240 V ac, 50-60Hz, 3.5 A  
Product Features Power Factor Correction (PFC)

## Cooling

Forced air, temperature controlled, heatsink temperature monitored via RS232 GUI interface.

## Acoustic level

45dBa @ Max Fan Speed @ temp.

## Case

Designed to meet EMI and RFI shielding requirements aluminum chassis. Front Panel: plastic overlay with membrane switches.

## Dimensions

H135mm x W211mm x L445mm  
( 5.25" x 8.3" x 17.5" )

## Weight

9 kg, 20 lbs.

## Mounting

Half Rack, 3U high. Optional: Rack Mount Kit, Adapter Kit, Coupling Screws.

## Environmental conditions

**Temp.:** 0° to 40° C ambient

**Humidity:** 80%

Equipment intended for ISM applications in laboratory and light industrial environment.

# Functional Block Diagram

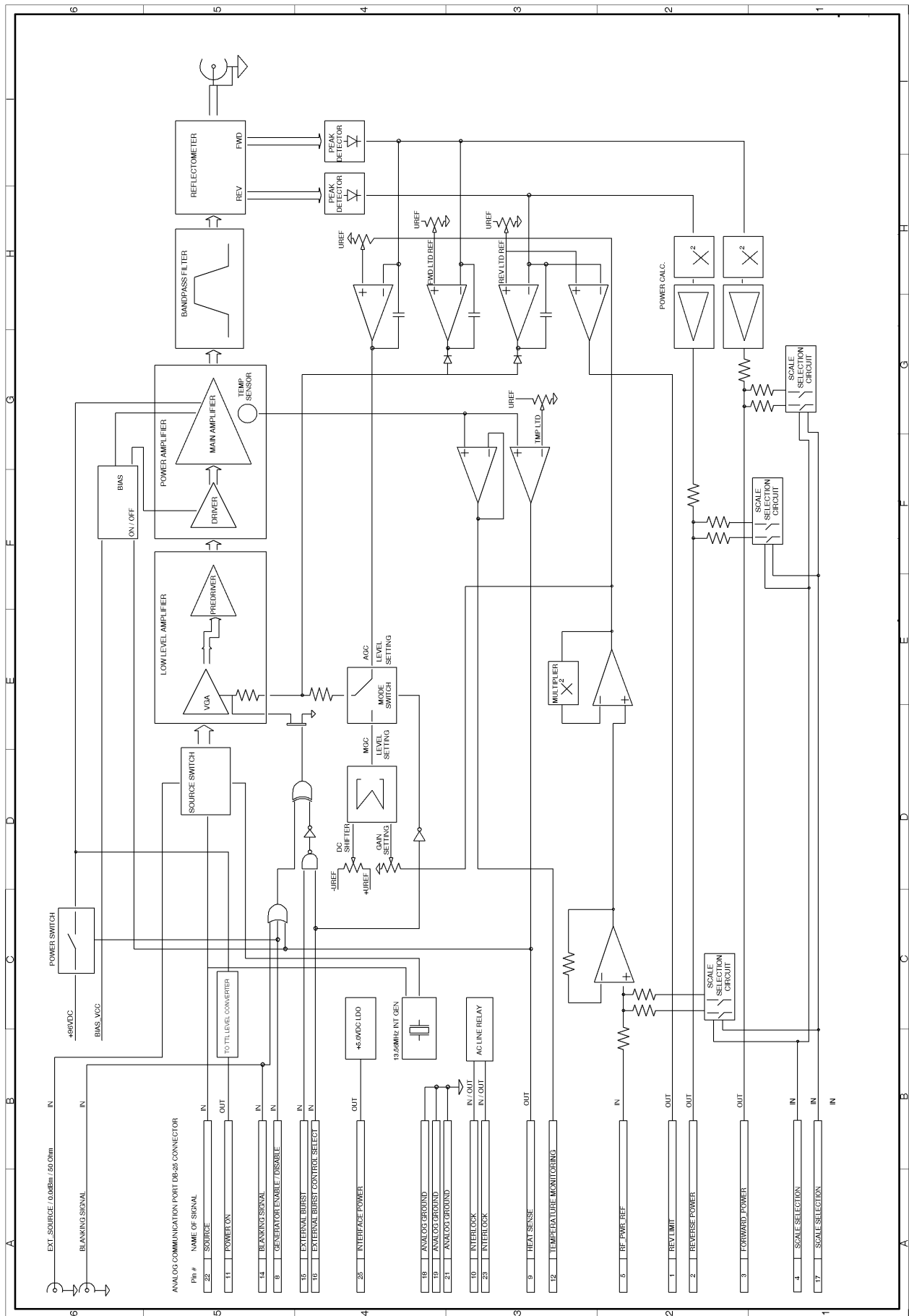

MIN 6" CLEARANCE FOR AIR EXHAUST

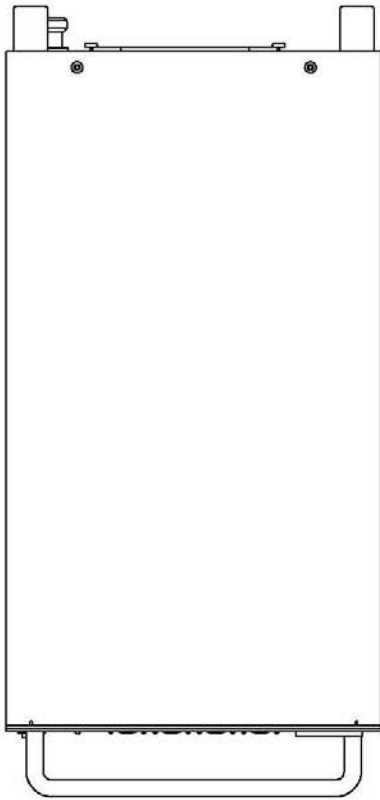

MIN 6" CLEARANCE FOR AIR INTAKE

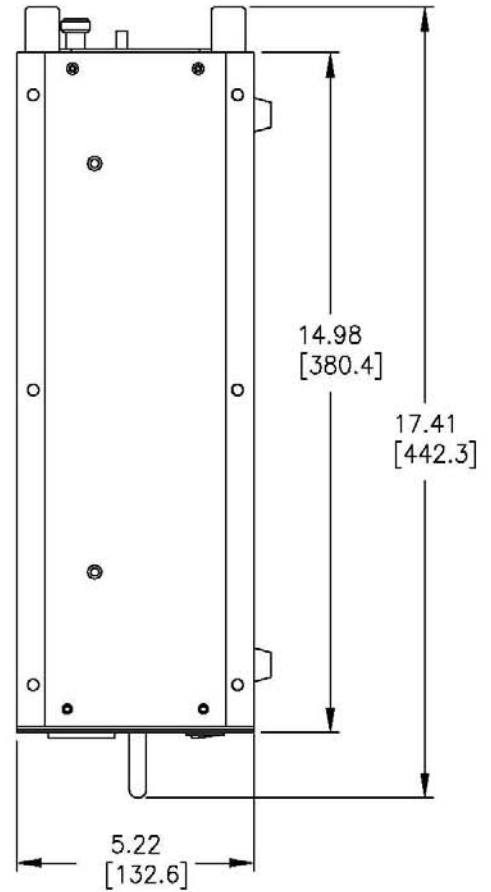

FRONT PANEL

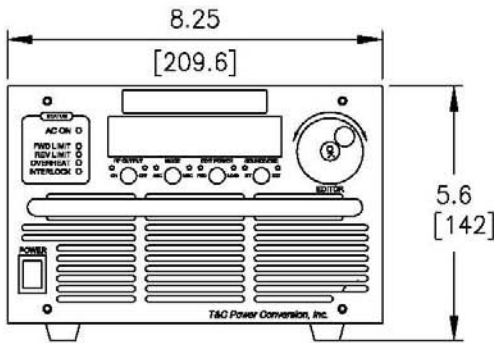

BACK PANEL

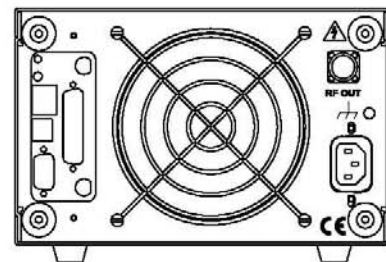

THIS DRAWING IS PROPERTY OF T&C POWER CONVERSION, INC. AND CAN NOT BE DISCLOSED OR REPRODUCED WITHOUT PRIOR WRITTEN AUTHORIZATION BY T&C POWER CONVERSION, INC.

MOUNTING AND OUTLINE  
AG0x13

**T&C Power Conversion, Inc.**  
110 Halstead Street, Suite 7, Rochester, NY 14610

APPROVALS	DATE
DRAWN <b>RMS</b>	01/15/09
CHECKED	
ISSUED	

SIZE A	DWG. NO. 9100 0211 92	REV. A
SCALE NONE	SHEET 1 OF 1	

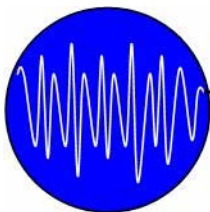

## **T&C Power Conversion, Inc.**

110 Halstead Street  
Rochester, New York 14610 USA  
e-mail: sales@TCPowerConversion.com

Phone: 1 585 482 5551  
Fax: 1 585 482 8487

**EC Declaration of Conformity**  
according to 98/37/EC  
according to EC EMC Directive 89/336/EEC  
And according to EC Low Voltage Directive 73/23/EEC

We, *T&C Power Conversion, Inc.*

of *110 Halstead Street, # 7*  
*Rochester, NY 14610, USA*

herewith declare, that the following product complies with the appropriate basic safety and health requirements of the EC Directive based on its design and type, as brought into circulation by us. In case of alteration of the product, not agreed upon by us, this declaration will lose its validity.

**Product Description:** RF Power Source

**Model Number:** 0313, 0313 D-Com, AG 0313

**Applicable EC Directive(s):** 73/23/EEC - The Low Voltage Directive  
and its amending directives

89/336/EEC - The Electromagnetic Compatibility Directive  
and its amending directives

**Applicable Harmonized Standards:** EN 61010-1:2001 (2nd Edition)  
EN 61326-1: 1997 + A1:1998 +A2:2001 +A3:2003

**Authorized Signature:** *Tomasz Mokrzan*      **Date:** 11/05/07

**Name:** Tomasz Mokrzan

**Title of Signatory:** General Manager

**CE 07**