

***T&C Power Conversion, Inc.***

110 Halstead Street  
Rochester, New York, 14610 USA

Phone: 1-716-482-5551  
FAX: 1-716-482-8487

E-Mail: Sales@TCPowerConversion.com

# ULTRA 2021

## LINEAR AMPLIFIER

# OPERATION MANUAL



**We offer various electronic products and engineering services: RF Linear Amplifiers, RF Power Drivers, AC to DC Power Supplies, Microprocessor Based Controllers, Analog Instruments . . .**

**IF YOU CAN'T FIND IT, WE WILL DESIGN IT!**

# Table Of Contents:

<u>Topic:</u>	<u>Page:</u>
• APPLICATIONS	3
• INSTALLATION	3
• SPECIFICATIONS	4
• OPERATION	5
• REMOTE CONTROL	6
• REAR PANEL CONNECTOR	7
• RS-232 OPERATION	9
• AGC CONTROL	8
• GUI DISPLAYS	10
• COOMUNICATION PROTOCOL	11
• SAFETY	13
• WARRANTY	13
• SERVICE	14

## Applications:

The *ULTRA 2021* is a general-purpose low frequency, air-cooled amplifier suitable for a broad range of uses including:

- *Ultrasonic Power Delivery*
- *Optical and Laser Component Excitation*
- *RFI / EMI Susceptibility Testing*
- *Medical Applications*
- *Materials Testing*
- *Manufacturing Processes*

## Installation:

The ULTRA2021 is designed for bench operation. To guarantee the best performance, make sure there is adequate clearance for the entrance of cooling air to the front of the unit as well as for the exhaust out the back of the unit. (6"min.)

The ULTRA2021 is usually set for operation with a single phase, 47 – 63 Hz AC Line of 90 to 132 VAC. Unit does not require any special internal adjustments if operated within the specified voltage range. The ULTRA2021 may also be operated from 180 to 264VAC by changing a jumper location on the two internal power supplies. (Position E14 = 90 –132 VAC and E13 = 180 – 264 VAC). Label on rear is marked with factory setting.

### **Please check the following items before applying AC power to the ULTRA2021:**

- *Check Unit for any physical damage that could affect safety.*
- *Ensure the AC power cord is an IEC type with a 10 Amp or greater rating with a proper safety ground connection.*
- *Ensure the AC power cord is plugged into a properly grounded outlet.*
-  *Connect ULTRA2021 chassis to a proper safety ground. (Use Grounding Stud on rear panel) A green insulated 18-gauge wire or heavier less than 50 feet in length is recommended.*

## Specifications:

<b>Class of Operation:</b>	“A” class in low power output, “AB” class at high power levels
<b>Frequency:</b>	10 kHz. to 15 MHz. minimum
<b>RF Output Power:</b>	100 W typical LINEAR, 300 W saturated in AB class
<b>Gain:</b>	53 dB, +/- 1dB
<b>RF Power input drive:</b>	-10 dBm to 0 dBm (1 mW) typical, +5 dBm max.
<b>AGC Operation:</b>	+ / - 0.3 dB, at drive level of -7dBm to -10 dBm
<b>Input &amp; Output Impedance:</b>	50 Ohms
<b>Input &amp; Output VSWR:</b>	1.2:1 max input; 3:1 max output
<b>Output VSWR Protection:</b>	75 W maximum reflected power internal limit
<b>Harmonic Level @ 50 Watts:</b>	> - 30 dBc, -20 dBc or better for third harmonic
<b>Spurious Output:</b>	Greater than - 55 dBc
<b>RF POWER Meter accuracy:</b>	+ / - 3% Typical
<b>Load Mismatch Tolerance:</b>	Continuous
<b>Reflected Power Protection:</b>	75-Watts maximum
<b>RF Input / Output connectors:</b>	BNC female
<b>Operating Temperature:</b>	0°C to 40°C
<b>Acoustic Level:</b>	45 dBa @ Max Fan Speed & Temp
<b>Humidity:</b>	80 %
<b>AC input requirement:</b>	90 to 132 VAC, (factory setting); 47- 63 Hz 180 to 264 VAC, (with jumper change); 47- 63 Hz.
<b>Circuit Protection:</b>	Internally fused at the DC power supplies. two # 314015 & one 250VT12A (internal)
<b>Power Connection:</b>	EMI / RFI Filter with IEC Standard Power Entry
<b>Cooling:</b>	Forced Air, temperature controlled
<b>Dimensions:</b>	H 135 x W 360 x 385 mm. (H 5.25” x W 14” x D 15”)
<b>Weight:</b>	~ 13 kg (28 lbs.)
<b>Mounting:</b>	Tabletop / stand-alone unit. (Other options available per customer specification.)
<b>Case:</b>	Chassis: yellow iridite, Front Panel: T & C off-white, Cover: T & C glossy black  Chassis designed to meet EMI RFI shielding requirements

## Operation:

The *ULTRA2021* is a bench top mounted laboratory amplifier with straightforward front panel features. On the left end of the front panel is the **AC line** power ON / OFF switch. This heavy-duty double pole switch connects and disconnects the hot and neutral power line connections. The amplifier is shipped from the factory internally wired for 90 - 132 VAC operation. Moving a jumper on the internal power supplies is necessary for operation from 180 - 264 VAC.

The red indicator lamp shows that AC power is connected to the unit, the power switch is on and the DC power is available to the amplifier. The amplifier has 50-Ohm BNC-type radio frequency coaxial connectors on the front panel for easy connection of the driving signal source and for the connection of the load. The user must make sure that connecting cables are also 50-Ohm types particularly for the output connection so that power is not reflected back to the amplifier due to cable impedance mismatch.

Forward RF power is continuously measured and indicated on the **digital forward power meter**. Reverse (reflected) power is likewise displayed on the **reverse power meter**. In normal operation, the forward power is at a maximum proportional to the driving signal applied to the input while the reverse power is a relatively small portion of that power. Few loads are perfectly resistive and exactly 50 Ohms so some reflected power is typical. The opposite extreme, a faulty load (either open or shorted) results in a significant reflective power typically near the level of the forward power. The continuous and highly visible real time displays of simultaneous forward and reflective power is a great benefit in monitoring a radio frequency power delivery system.

A wide area of ventilating holes serve as the air intake for ventilating the amplifier. Linear class "A" operation has low distortion benefits and necessitates removal of the heat generated by this bias mode. ***The air intake must be kept clear of obstructions*** as should the fan outflow at the rear of the unit. Allow a minimum of 6" clearance around all sides of the chassis. The fan's speed is proportional to the temperature rise of the internal heat sink. There is also a high temperature cut out switch that shuts down the amplifier if the heatsink gets too hot. This could happen; for example, if the intake airflow is obstructed.

***Other front panel status indicators:*** are the green led labeled "**A.C. ON**". Its purpose is to show when the amplifier is under **Automatic Control** from the rear panel interface. When this led is on the amplifier is in the automatic power leveling mode. The **red led** labeled "**Overheat**" glows if the internal heatsink temperature rises to an excessive temperature. Operation should be discontinued until the cause is determined and ventilation of the unit is restored. The **yellow indicator** glows when the **reverse limit** of power is reached. High reflective power causes additional heat and is stressful to internal components. In order to protect those devices, an automatic circuit reduces the gain of the amplifier if excessive amounts of power are reflected back to the amplifier from a faulty load or cable.

On the rear Panel of the amplifier there is a female 25 pin D style connector for remote monitoring and control. A label describes the pin functions assigned to the connector. Additional details are provided in the following table.

## Remote Control:

**Description:** These additional features are provided by use of the Remote Control:

- *Power Leveling within + / - 0.5 dB. From 10 kHz to 12 MHz min.*
- *Remote power level adjustment and control.*
- *Remote access to forward and reverse power level information.*
- *Status flags indicating power on, thermal limit, reverse power limit.*

**Operation:** To enable remote operation, the remote control signal must be asserted (+5 Volts) at pin 8 of the rear panel connector. To remotely control the amplifier's power level, pin 5 must be provided with a DC voltage proportional to the RF power level desired. Refer to the table of panel connector pin descriptions on page 6 of this manual.

Under remote control, the final output power level is still partly dependent upon the drive level provided to the front panel input connector. This is necessary due to the finite power gain of the amplifier. In most applications it is desirable to start with a drive level in local control that produces half the maximum power that may be desired under remote control. This ensures that there is sufficient drive at the amplifiers input for remote control to attain the full range of remotely set power. For example, to be able to vary the output power level from zero to 10 Watts remotely, the drive level could be made – 7 dBm. This is estimated as follows: A maximum power of 100 Watts is 50 dBm. Half of that power is 47 dBm (50 Watts), subtracting the amplifier's gain (54 dB) yields an input power level of – 7 dBm.

The preceding discussion provides a good starting point though any output power level can be reached with different combinations of input drive level and remote power control voltage. In applications where minimum signal distortion is of special importance, the combination may be altered. This is particularly useful in fixed frequency applications. Optimal levels for frequency swept use are best judged empirically.

The rear panel connector's socket pins are numbered 1 to 13 reading from right to left across the top row. Returning to the right, the bottom row is 14 to 25.

A simple test circuit for remote power adjustment uses a multiturn 10 K potentiometer wired as follows: CCW terminal to pin 12 (AGND), CW terminal to (+5 Volts) and pin 8 (EXT. CONT. SEL.), and the wiper of the pot connected to pin 5 (RF control input).

## Rear Panel Connector, Analog DB-25 Option:

Pin #	Name of Signal	Signal Description
1	<b>REV LIMIT</b> This output indicates that output power level was automatically reduced under load mismatch condition.	TTL Compatible; 5V = RF Out Limit, 0 Volts = Normal operating condition at low VSWR <b>Signal Direction: OUT</b>
2	<b>REVERSE POWER METER</b>	Linear voltage output, 1Vdc = 100W <b>Signal Direction: OUT</b>
3	<b>FORWARD POWER METER</b>	Linear voltage output, 1Vdc = 100W <b>Signal Direction: OUT</b>
5	<b>EXTERNAL RF PWR REF - optional part of AGC</b>	Linear voltage input, 1Vdc = 100W (with 0 dBm input) <b>Signal Direction: IN</b>
18, 19 21	<b>ANALOG GROUND</b>	Signal Common
8	<b>EXTERNAL CONTROL SELECT</b> (part of AGC option)	TTL compatible input: Hi = remote control active Lo = remote control disabled <b>Signal Direction: IN</b>
9	<b>HEAT SENSE:</b> This output indicates that the unit has become too hot.	TTL compatible output: Hi = HOT!, Lo = Normal temperature <b>Signal Direction: OUT</b>
11	<b>POWER ON:</b> DC power applied to control circuit. Indirect meaning: AC is ON.	TTL compatible output: Hi = Power ON, Lo = Power Off <b>Signal Direction: OUT</b>
14	<b>AMPLIFIER DISABLE / ENABLE</b> Open Collector	Open = Enable      Closed = Disable <b>Signal Direction: IN</b>

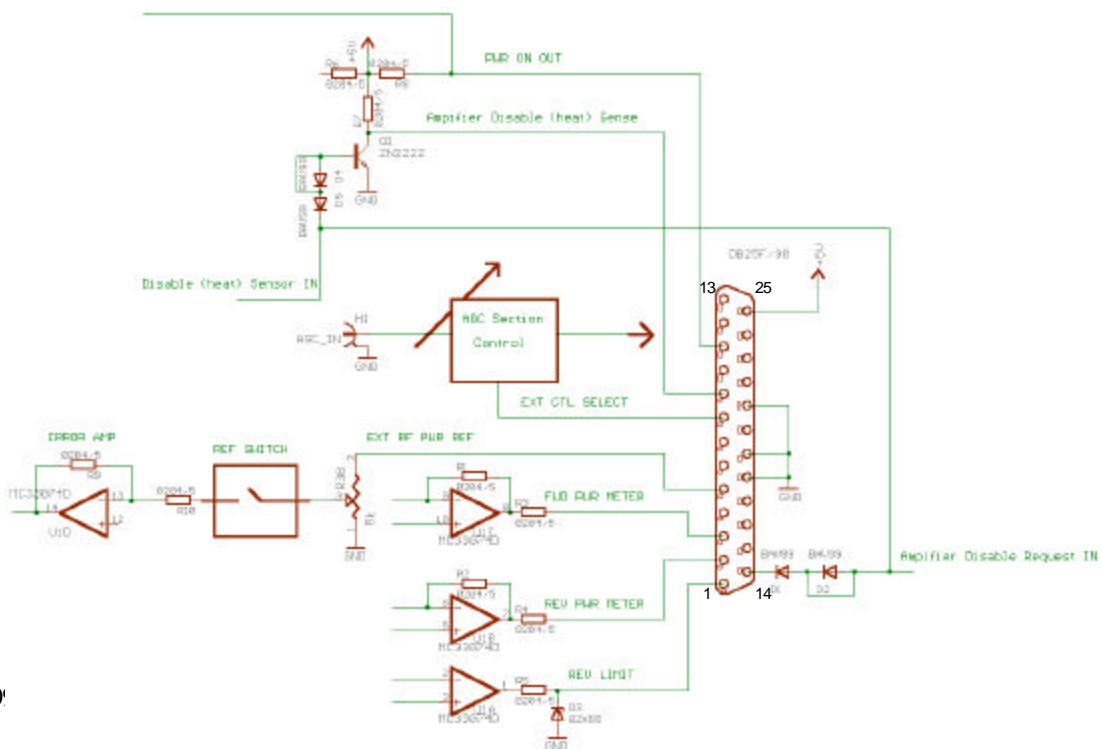

## Rear Panel SubD9 RS232 I/O Connector Signal Description Table

Pin #	Name of Signal	Signal Description
2	<b>RxD</b> Data from Controller to PC	RS 232 signals <b>Signal Direction: Out</b>
3	<b>TxD</b> Data from PC to Controller	RS 232 <b>Signal Direction: Input</b>
5	<b>GND</b>	GND <b>Signal Direction: I/O</b>
1, 6, 7	Quasi HANDSHAKING for PC	Pins shorted on Controller side <b>Signal Direction: Out</b>
4, 8	Quasi HANDSHAKING for PC	Pins shorted on Controller side <b>Signal Direction: Out</b>

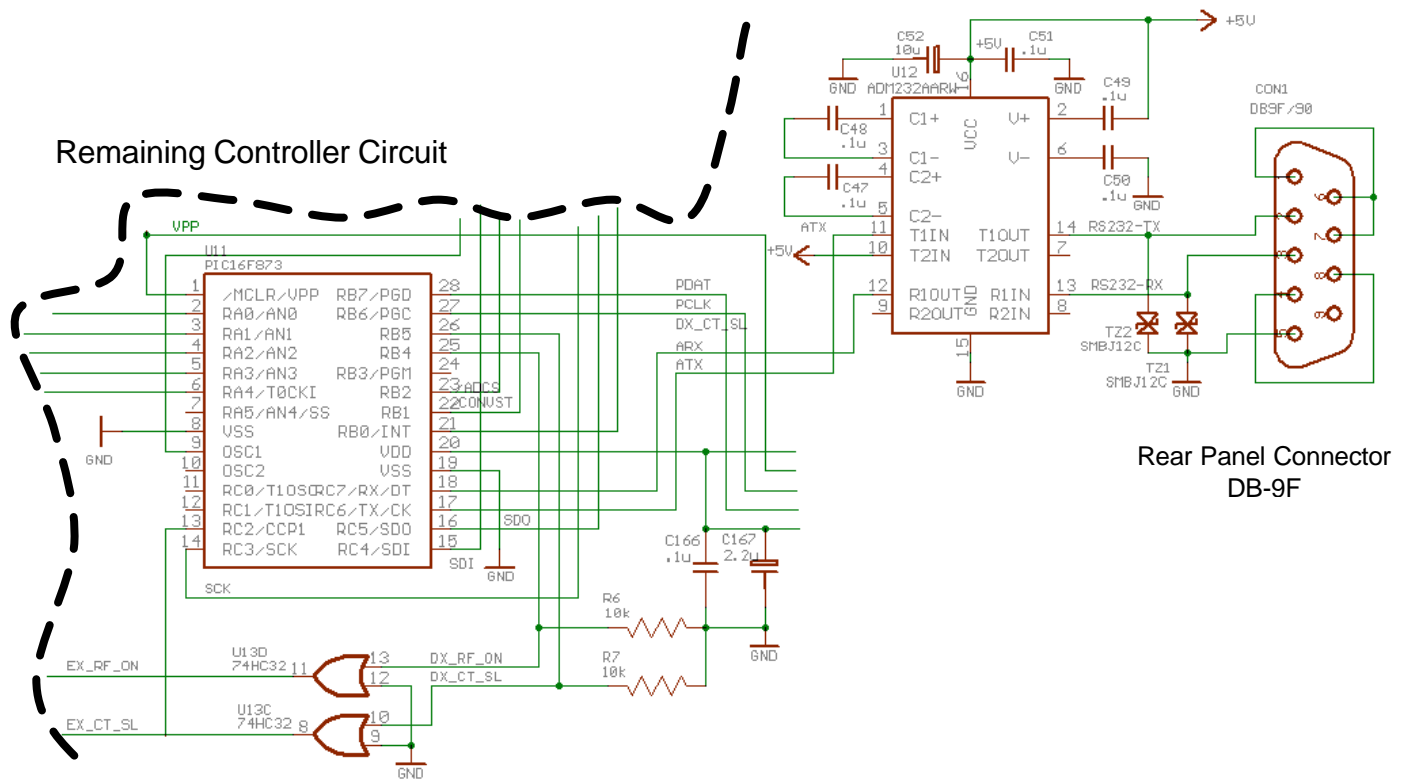

## RS-232 OPERATION

RS-232 option:

1. Connect cable from Comm port of computer to RS-232 connector on rear of amplifier unit.
2. Power ON computer and load T&C supplied software in disk drive.  
(Program may be transferred to hard drive)
3. Access Disk and run program  
**Screen A** will be displayed
4. Amplifier Power on
5. Install program: RUN:/C:/folder name TCCP071.exe  
**Screen B** will be displayed
6. Select proper Comm port for your PC.  
(Select COMM, then select proper port)
7. **Screen B** will show actual amplifier operation and settings

When amplifier is turned on, as above, it's normal mode of operation is fixed gain.

NOTE: UNIT IS CALIBRATED AT FACTORY

8. Apply RF signal to input connector. The signal should be from  $-6$  dBm to  $-10$ dBm and within the frequency range of the amplifier. **CAUTION: There will be an output. The amplifier should be terminated into a load before signal is applied.**
  9. **Screen C** will show actual amplifier operation. Forward and Reflected power will be displayed. If Load power display has been selected, it will also show a value, if present.
  10. Select AGC ON: The power will change to the value displayed in the AGC Control block.
  11. Choose and enter desired output power in section labeled AGC Control
  12. Forward Power will change to selected value and display will reflect that change.
  13. The power output can be changed in increments of 1 or 10 Watts. If the value is to be changed by 1-Watt increments, click the MPY button until X1 is displayed. The up/down arrows can be used to increase or decrease the setting by the 1-Watt at a time. This will not change the output until the SET button is selected. The selection can be canceled by selecting the Esc X button.
  14. Turn the Automatic Gain Control off using the AGC ON/OFF button. **Screen E**
- NOTICE: If the computer is disconnected or the program is terminated, the amplifier will operate under the last transmitted conditions. Turning the amplifier off and on, or reinitializing the control program will be necessary to change the amplifier operating settings.
15. When turned off or in overheat condition, the READY light will turn Red. **Screen E**

**Initial GUI Screen. When first started this screen will be displayed.**

**A**



**Initial Control GUI Screen. Will appear when the software is loaded.**

READY "green" lamp ON.

**B**



**Typical Power reading screen. 50 Ohm Load.**

READY ON – Green,  
FWD Power Light Green Bar active,  
REV Power Orange (if any to measure)  
LOAD (option active) Dark Green.  
Unit operating in Fixed Gain Amplifier.

**C**

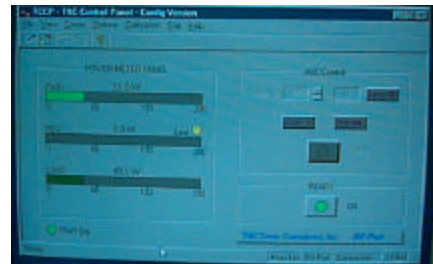

**Typical Power reading screen. 3:1 VSWR, 17 Ohm.**

READY ON – Green,  
FWD Power Light Green Bar active,  
REV Power Orange,  
LOAD (option active) Dark Green.  
**Unit operating in AGC ON – external AGC Mode.**

**D**

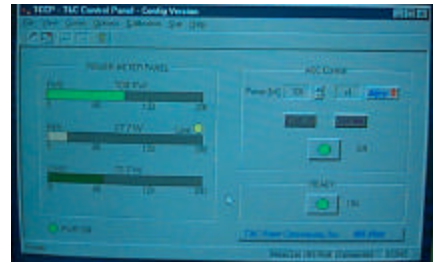

**Amplifier in READY OFF/HEAT mode by:**

1. user request or,
  2. Internally overheat condition
- DISPLAY: No power readings  
Ready OFF – Red

**E**



# Communication Protocol Controller RSPort V.1.00

## 1. Introduction.

Communication between HOST (ex. PC) and the amplifier controller use asynchronous transmission protocol. Setup of the communication port should look like the example:

- Bits per second            19.200 BPS,
- Data bits                    8,
- Parity                        NONE,
- Stop bit                     1,
- Flow controls                NONE,

Host using the frames to send information for receiver. The polling protocol is used for communication. The host is working as a Master. Host initializes all information. Controller (Slave) can't send a frame. If Host sends an incorrect frame, the slave sends a frame REJ.

## 2. RS232C logic waveform.

The communication protocol is using 5 frames:

- |      |                  |  |
|------|------------------|--|
| HEAD | - 1 byte         | - introduction of frame=96H,   |
| LEN  | - 1 byte         | - length of frame,   |
| CTRL | - 1 byte         | - code of operation,   |
| DATA | - <0 , 12> bytes | - parameters of operation. When sending more than one byte, use direction from LSB to MSB. |
| CRC  | - 1 byte         | - the control sum,   |

### 3. Used frames.

<b>FROM HOST TO CONTROLLER</b>			
<b>Mnemonic</b>	<b>CTRL</b>	<b>LEN</b>	<b>Definition</b>
SetCONFIG	0	3	Set controller configuration
SetPAGC	3	4	Set power level for AGC mode.
SetAPX	6	14	Set apx record.
SetSKEY	7	3	Set soft key.
GetCONFIG	16	2	Get controller configuration.
GetPAGC	19	2	Get power level for AGC mode.
GetAPX	22	3	Get apx record.
GetSKEY	23	2	Get soft key.
GetSVER	29	2	Get controller Soft/Hard version.
GetMEAS	30	2	Get measurements.
GetSTA	31	2	Get status.
<b>FROM CONTROLLER TO HOST</b>			
ShowCONFIG	0	3	Show controller configuration.
ShowPAGC	3	4	Show power level for AGC mode.
ShowAPX	6	14	Show apx record.
ShowSKEY	7	3	Show soft key.
ShowSVER	13	8	Show controller Soft/Hard version.
ShowMEAS	14	5	Show measurements
ShowSTA	15	10	Show status.
REJ	42	2	Unknown frame.

## Safety:

**Do not operate this amplifier with the cover removed.** Lethal voltages are present beneath the cover. The cover protects against **electrical shock** due to AC line voltage, high RF potential in the hundreds of Volts at the output transformer, coupler and output connections. Also the DC supplies produce high voltages in the conversion process and are capable of producing more than 25 Amps of current at nominal output voltage.

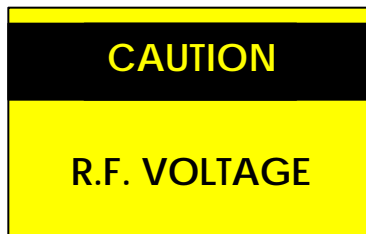

The cover is an integral part of the air ducting system that keeps components cool. Without the cover in place, insufficient air flows between and around the two DC power supplies causing overheating of the internal components.

This label should remain affixed to the front panel just below the RF output connector. Always connect the load to the RF output connector before connecting the RF input to the amplifier. This will ensure that high voltage at the center pin of the output BNC connector will not be exposed. Take care not to interchange the input and output cables.

Be sure the chassis is grounded to a reliable earth ground using the grounding stud provided on the rear panel. In addition, be sure the grounding wire remains connected securely between the cover of the chassis and the base of the chassis.

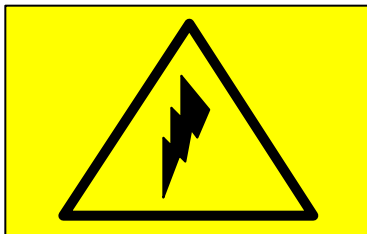

Wherever this label appears, refer to corresponding cautionary information in the operators manual.

## Warranty:

T & C Power Conversion warrants to the original purchaser for a period of one year from the date of delivery each instrument to be free from defects in materials and workmanship. For a period of one year, T & C will adjust, repair or replace defective parts, without charge to the original purchaser, so that the instrument performs according to its specifications.

If, in our opinion, the instrument has been damaged by accident, unreasonable use, buyer-supplied software or interfacing, improper site preparation or maintenance, or abnormal conditions of operation, repairs will be billed at standard rates. In this case, an estimate will be submitted before the work is started.

## Service:

All repairs should be referred to the factory. There are no user serviceable parts or adjustments internally. If repair should be needed, pack the unit in its original packing carton using the padding provided and ship the unit to:

Returns Department  
T & C Power Conversion Inc  
110 Halstead Street  
Rochester, NY 14610

Standard service for all out of warranty repairs will be billed at T&C's in-house standard repair rate. Call for current rates and turn-around time. (716-482-5551) Factory repairs of repeat or related failures are warranted for 90 days.

### Standard service includes:

- *Thorough evaluation by the T&C Engineering Department*
- *Original top quality parts used*
- *Repairs with standard factory procedures*
- *12 hour burn-in to ensure reliability*
- *Quality control audit*
- *Calibration to meet current specifications*
- *Latest upgrades available*